



MODEL WCSP-J SYSTEM INSTALLATION, OPERATION & MAINTENANCE MANUAL

**Central Hydronic Coil Series
2 to 5 Tons
Fan Coil Unit/Air Supply
Components**



SECTION 1: INTRODUCTION		Step 9: B & C Series Retrofits17-19	
SpacePak System Design	2	SECTION 3: START UP & OPERATION	
Code Compliance	2	Sequence Of Operation	19
Air Distribution Requirements	2	Prior To Start-Up	19
Air Distribution Components	3-5	System Start-Up & Adjustments	19
Shipment of Unit	5	Operating Setpoints	21-23
SECTION 2: SYSTEM INSTALLATION		Factors Affecting the Balance of the System.....	24
Step 1: Locating The Unit	5	SECTION 4: MAINTENANCE	
Step 2: Cutting Return Air Opening	8	Yearly Maintenance Checklist.....	25
Step 3: Attaching Supply Air Plenum Adaptor	9	If System Fails To Operate	25
Step 4: Setting The Unit	10	Service/Troubleshooting Form.....	26
Step 5: Connecting Water Lines	11	Parts List.....	27
Step 6: Installing The Condensate Trap & Line...	11	Warranty Information	28
Step 7: Wiring The Unit	11-12		
Step 8: Installing Air Distribution Components	13-19		



IN UNITED STATES: 260 NORTH ELM ST. WESTFIELD, MA 01085 (413) 564-5530/FAX (413) 564-5815
 IN CANADA: 7555 TRANMERE DRIVE, MISSISSAUGA, ONTARIO, L5S 1L4 (905) 670-5888/FAX (905) 670-5782



Section 1: INTRODUCTION

The following terms are used throughout this manual to bring attention to the presence of potential hazards or to important information concerning the product:

▲ DANGER Indicates an imminently hazardous situation which, if not avoided, will result in death, serious injury or substantial property damage.

▲ WARNING Indicates an imminently hazardous situation which, if not avoided, could result in death, serious injury or substantial property damage.

▲ CAUTION Indicates an imminently hazardous situation which, if not avoided, may result in minor injury or property damage.

NOTICE: Used to notify of special instructions on installation, operation or maintenance which are important to equipment but not related to personal injury hazards.

SPACEPAK SYSTEM DESIGN

The SpacePak WCSP-J unit is a hydronic fan coil unit which utilizes chilled or heated water from a chiller or boiler to provide the conditioned air through the specially designed prefabricated preinsulated flexible duct system. The system and its basic components operate the same as in any conventional air-to-air cooling system.

The SpacePak system is covered by the following U.S. Patents: 3,507,354; 3,575,234; 3,596,936; 3,605,797; 3,685,329; 4,045,977; 4,698,982; 926,673 and Canadian Patents: 891,292; 923,935; 923,936.

CODE COMPLIANCE

Fan coil unit installation must conform to the requirements of the local authority having jurisdiction or, in the absence of such requirements, to the National Board of Fire Underwriters regulations. Fan coil unit meets ETL listing requirements.

All electrical wiring must be in accordance with the National Electrical Code ANSI/NFPA No. 70-latest edition and any additional state or local code requirements. If an external electrical source is utilized, the fan coil unit, when installed, must be electrically grounded.

NOTICE: It is a requirement of the International Mechanical Code (307.2.3) to install a secondary drain or an auxiliary drain pan where damage to any building components will occur as a result of overflow from the equipment drain pan or stoppage in the condensate drain piping from a cooling or an evaporator coil.

AIR DISTRIBUTION SYSTEM COMPONENT REQUIREMENTS

Air distribution components installation must conform to the requirements of local authority having jurisdiction or, in the absence of such requirements, to the National Fire Protection Association 90A or 90B.

Do not begin the installation of the system without a system layout and material take-off. If a layout plan is not already available and room terminator requirements determined, then refer to the SpacePak Application Manual, SP9, to complete this information. A description of air distribution system components is shown in Figure 1.1.

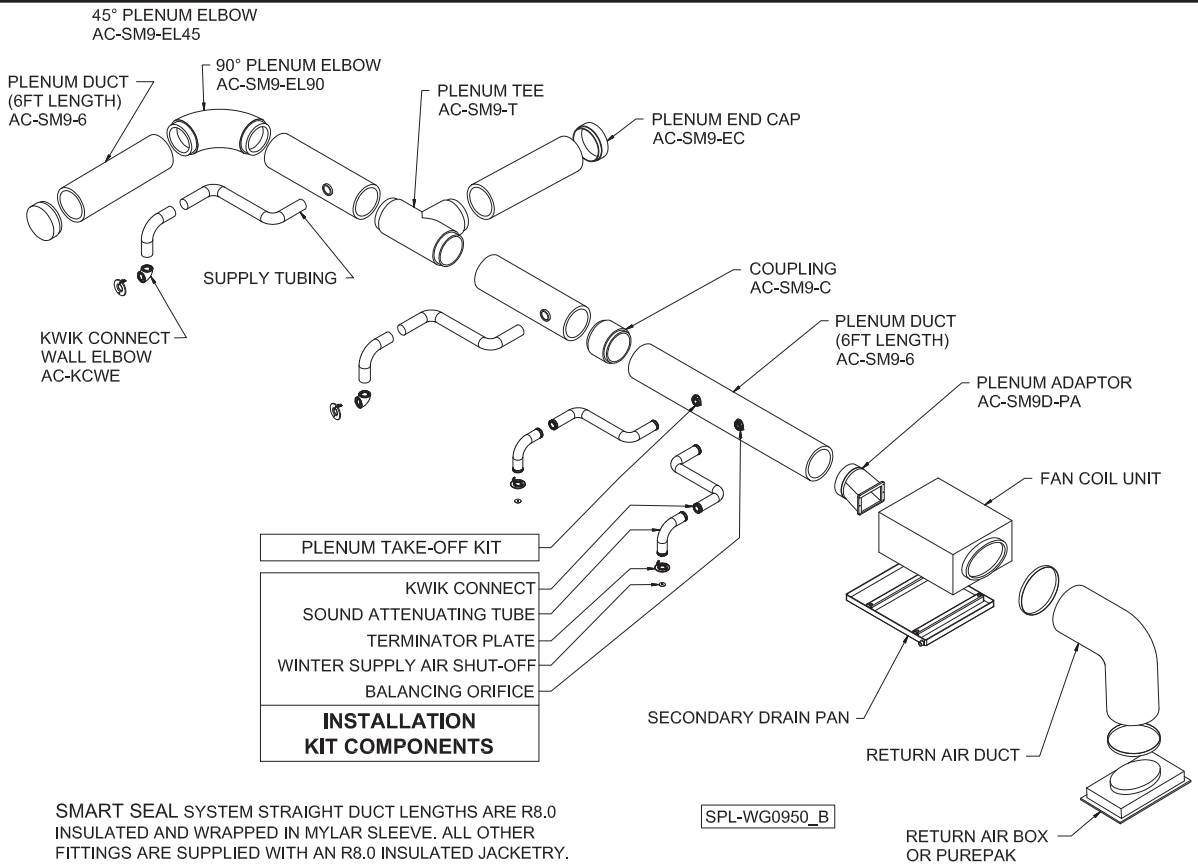

SMART SEAL SYSTEM STRAIGHT DUCT LENGTHS ARE R8.0 INSULATED AND WRAPPED IN MYLAR SLEEVE. ALL OTHER FITTINGS ARE SUPPLIED WITH AN R8.0 INSULATED JACKETRY. DUCT COMPONENTS SHOWN WITHOUT FACTORY SUPPLIED R8.0 INSULATED JACKETRY.

RETURN AIR BOX (SPC-1D, AC-RBF-3, SPC-3D): Each includes filter grill with metal frame, permanent filter, and 2 clamp bands. SPC-1D is for WCSP-2430. AC-RBF-3 is for WCSP-3642 and SPC-3D is for WCSP-4860.

RETURN AIR DUCT (SPC-4,5, & 6): Flexible, 10 feet long with round shape. SPC-4 (15" dia.) for WCSP-2430. SPC-5 (19" dia.) for WCSP-3642 and SPC-6 (24" dia.) is for WCSP-4860.

PLENUM ADAPTOR: 9" round OR 10" X 10" square metal component to attach plenum duct to fan coil unit.
Plenum Adaptor - 9" Round - AC-PAJ
Plenum Adaptor - 10" x 10" Square - AC-PAJSQ

PLENUM DUCT & COMPONENTS: May be SmartPak System Duct, 9" round sheet metal or 10" X 10" (O.D.) square, fiberboard duct types as specified by the installing contractor. Above layout is shown as an illustrative assembly reference only.

R6 SUPPLY TUBING (AC-ST6-100): Flexible, R6 insulated, 2" I.D. and 3-1/4" O.D. Each section is 100 feet long.

R8 SUPPLY TUBING (AC-ST8-75): Flexible, R8 insulated, 2" I.D. and 5-3/8" O.D. Each section is 75 feet long.

INSTALLATION KITS: Contains a specified amount of sound attenuating tubes, kwik-connects, terminator plates (incl. spring clips & screws), winter supply air shut-offs and a balancing orifice set to complete installation of room outlets. Supplied in (2) [AC-IKLT-2] and (5) [AC-IKLT-5] outlet boxed quantities.

PLENUM TAKE-OFF KIT: Contains a specific amount of plenum take-offs, gaskets and fasteners to complete installation of room outlets. Take-offs available for round or square duct as specified by installing contractor. Supplied in (2) [AC-TKMR-2] and (5) [AC-TKMR-5] outlet boxed quantities for round sheet metal and (2) [AC-TKFS-2] and (5) [AC-TKFS-5] outlet boxed quantities for square fiberboard.

KWIK CONNECT WALL ELBOW (AC-KCWE): To allow for wall terminations in 2" X 4" stud spaces.

SECONDARY DRAIN PAN: Specifically sized for SpacePak horizontal fan coil units. Constructed of durable polyethylene. Fan coil unit sets directly on top and can be installed with threaded rod.

PLIERS (SPC-72): To assure full setting of all clips (fasteners) in plenum take-off (not shown).

PLENUM HOLE CUTTER (SPC-71-10): To cut 2" hole in fiber board for plenum take-off installation (not shown).

FIGURE 1.1: AIR DISTRIBUTION SYSTEM COMPONENTS

Plenum Duct

The plenum duct can be run in practically any location accessible for the attachment of the supply tubing (see suggested layouts in Figure 1.2). The plenum is normally located in the attic or basement, and it is usually more economical to run the plenum where it will appreciably shorten the lengths of two or more supply runs.

In some two-story split level homes, it may be advantageous to go from one level to another with the plenum duct. Whenever necessary, either between floors or along the ceiling, the small size of the plenum makes it easy to box in.

The fan coil unit is designed to operate with a total external static pressure of 1.5 inches of water column (minimum 1.2 - maximum 1.5). Excessive static pressure is an indication of too few outlets and may cause the coil to freeze and some or all outlets to be noisy.

For systems with a bullhead tee installed as on Unit No. 1 (Figure 1.3), the best results are obtained if not more than 60% of the total number of system outlets are attached to any one branch of the tee. For systems with a branch tee installed as on Unit No. 2 (Figure 1.3), not more than 30% of the total number of system outlets should be attached to the perpendicular branch of the tee.

The larger system capacities (WCSP-3642/4860) are affected more by higher system static pressure than the smaller systems. The four and five ton systems are ideally designed as indicated by the diagram in the lower left corner of figure 1.2. If this layout cannot be followed, it is important to create some pressure drop in the plenum run using elbows and tees. Installation of the plenum tee closer than the minimum indicated in Fig. 1.3 will reduce performance of the system. No supply runs should be installed between unit outlet and this tee. Static readings on system should be taken before tee.

Supply Tubing

In the case of two-story or split-level applications, supply tubing may run from one story to another. It is small enough to go in stud spaces, but this is often difficult in older homes because of hidden obstructions in stud spaces. It is more common to run the supply tubing from the attic down through second story closets to the first story terminators.

Supply tubing runs in the corners of the second story rooms can be boxed in and are hardly noticeable since overall diameter is only 3-1/4" (Model Number AC-ST6-100).

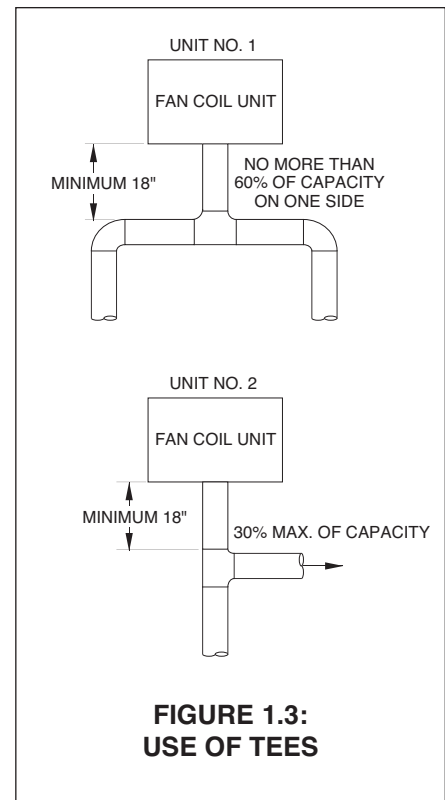
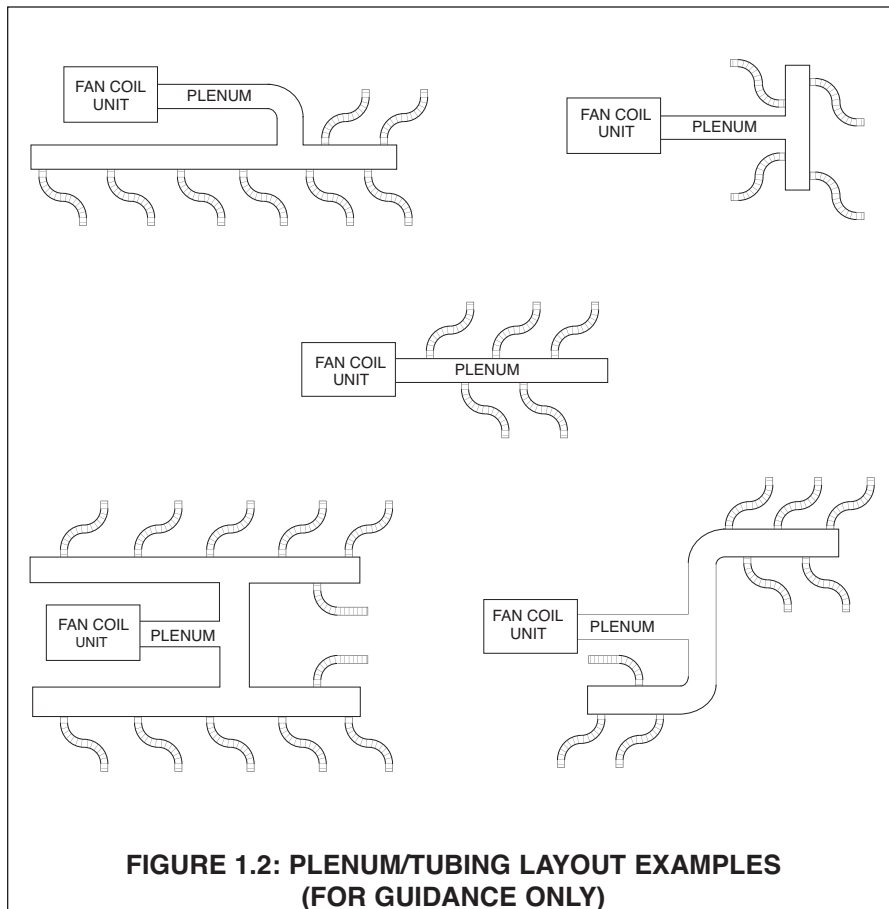

Room Terminators

Terminators should be located only in the ceiling or floor for vertical discharge. Horizontal discharge is acceptable, but is sometimes more difficult to install. Two excellent spots for horizontal discharge are in the soffit area above kitchen cabinets (see Figure 1.4) and in the top portion of closets (see Figure 1.5).

Terminators should always be out of normal traffic patterns to prevent discharge air from blowing directly on occupants. And they should not be located directly above shelves or large pieces of furniture. Outside wall or corner locations are recommended if the room has more than one outside wall. Locating terminators away from interior doors prevents short cycling of air to the return air box.

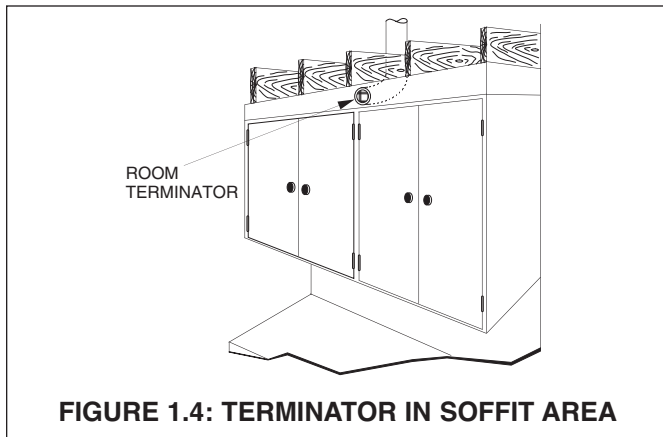

FIGURE 1.4: TERMINATOR IN SOFFIT AREA

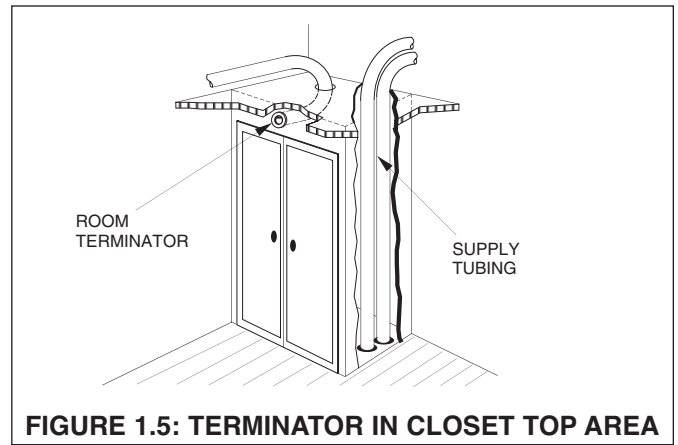

FIGURE 1.5: TERMINATOR IN CLOSET TOP AREA

SHIPMENT OF UNIT

Each fan coil unit is shipped in a single carton. Packed with the unit, there are vibration isolation pads, a condensate trap assembly and a factory installed primary float switch.

SECTION 2: SYSTEM INSTALLATION

NOTICE: Before proceeding with the installation, we recommend reading through this section of the manual for an overall understanding of the air conditioning fan coil unit and air distribution system component installation procedures.

STEP 1: LOCATING THE UNIT

The fan coil unit may be installed in an unconditioned space (as long as it is protected from the weather) such as an attic, garage or crawlspace, or a conditioned space such as a basement, closet or utility room (see dimensions in Figures 2.2 and 2.3).

When selecting a location, consider the locations (as shown in Figures 2.4, 2.5 and 2.6) of the return air box; routing of the plenum duct, supply tubing, refrigerant lines, condensate drain line; and all recommended clearances (see Figures 2.2).

Model	System capacity (Nom. Tons)	Electrical Characteristics*	Connections			
			Bottom Water In	Top Water Out	Cond. Drain (NPT)	Return Inlet (Dia.)
WCSP-2430J	2 - 2-1/2	230/1/60	7/8"	7/8"	3/4"	15"
WCSP-3642J	3 - 3-1/2	230/1/60	7/8"	7/8"	3/4"	19"
WCSP-4860J	4 - 5	230/1/60	7/8"	7/8"	3/4"	24"

Model	System capacity (Nom. Tons)	Blower				Coil		Ship. Wt. (lbs)
		Std. CFM @ 1.5" W.C.	Wheel Dia. and Width	Motor HP	115V/230V F.L. Amps*	No. of Rows Deep	Flow Rate per Ton (GPM)	
WCSP-2430J	2 - 2-1/2	440, 550	10" x 6"	3/4	5.6/2.8	6	2.4	105
WCSP-3642J	3 - 3-1/2	660, 850	10" x 6"	3/4	7.6/4	6	2.4	123
WCSP-4860J	4 - 5	880, 1150	10" x 6"	3/4	10.6/5.4	6	2.4	144

*Unit includes optional conversion kit to 115V.

FIGURE 2.1: MODEL WCSP-J SPECIFICATIONS

MODEL	A	B	C	D
WCSP-2430J	24-1/4"	12"	18-1/2"	10-1/2"
WCSP-3642J	33-1/4"	16-1/2"	25-3/4"	10"
WCSP-4860J	43-1/4"	21-1/2"	34-1/4"	10-1/4"

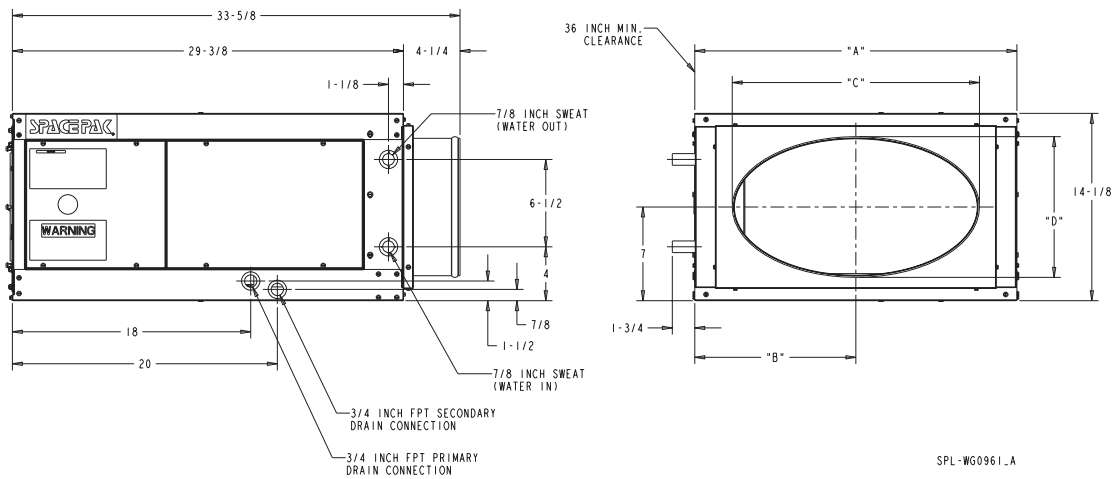

FIGURE 2.2: UNIT DIMENSIONS AND CLEARANCES (Inches)

MODEL	A	B	C
2430J	10-1/8"	4-7/8"	9-1/2"
3642J	12"	11-7/8"	14"
4860J	17"	17"	19"

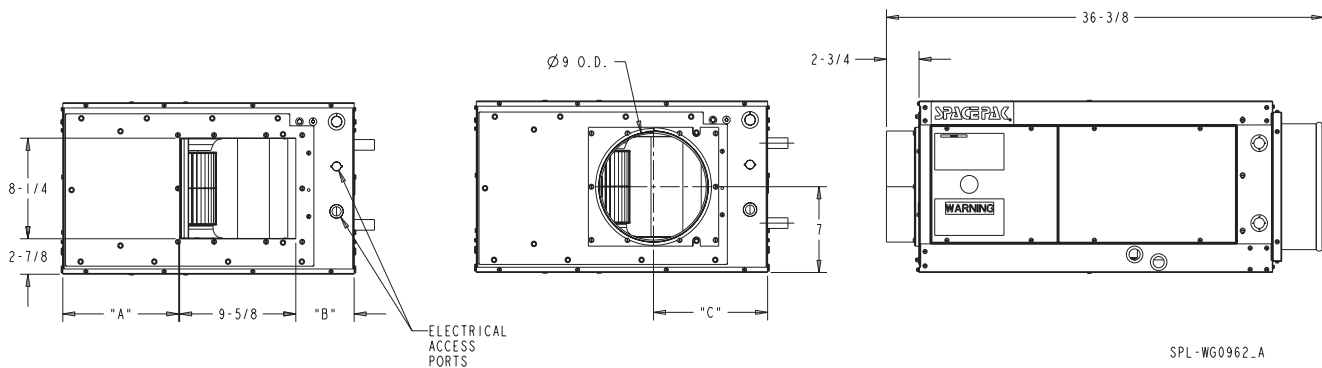
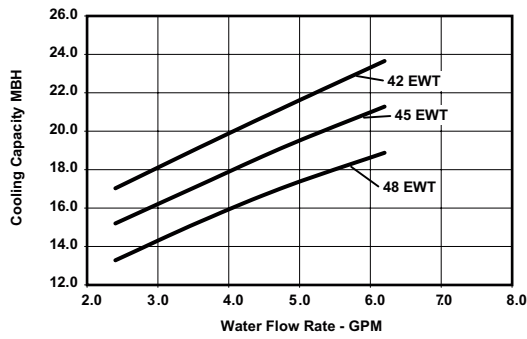
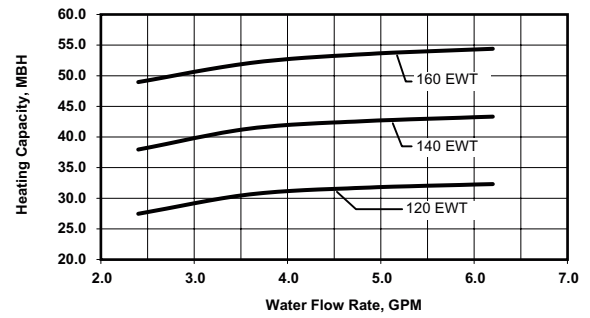

FIGURE 2.3: CONNECTION LOCATIONS AND ASSEMBLED PLENUM ADAPTER DIMENSIONS

WCSP-2430 @ 550 cfm Cooling Capacity



WCSP-2430 @ 550 cfm Heating Capacity



WCSP-3642 @ 850 cfm Cooling Capacity

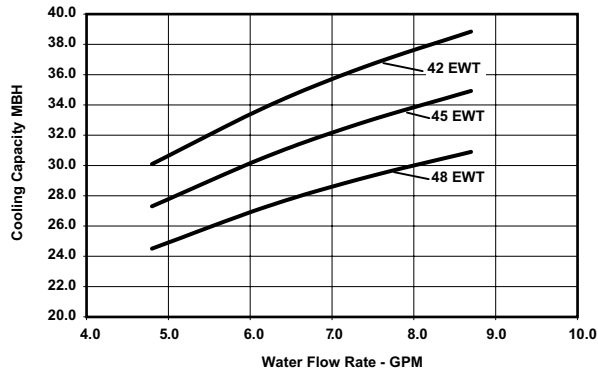

WCSP-3642 @ 850 cfm Heating Capacity

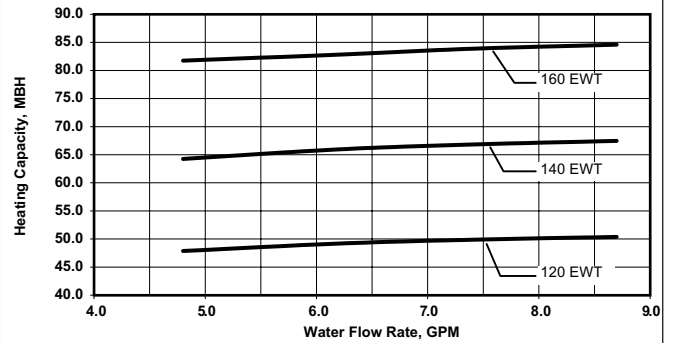

WCSP-4860 @ 1150 cfm Cooling Capacity

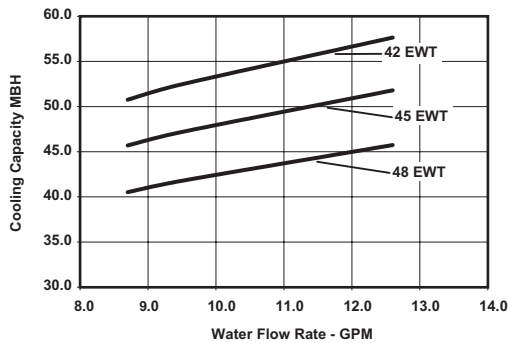

WCSP-4860 @ 1150 cfm Heating Capacity

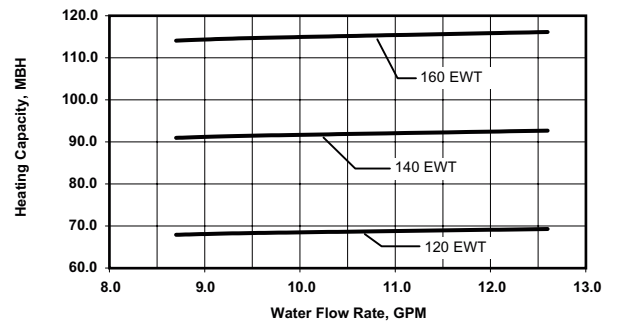

Hydronic Coil Pressure Drop Characteristics

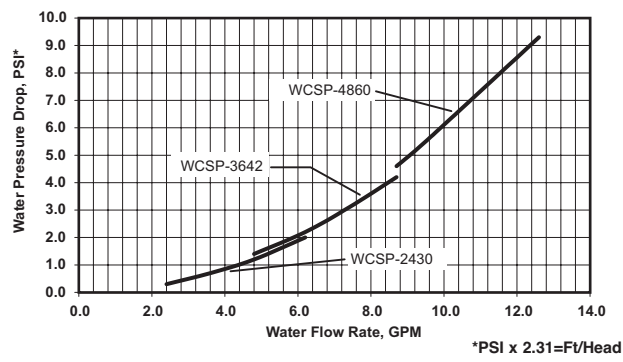

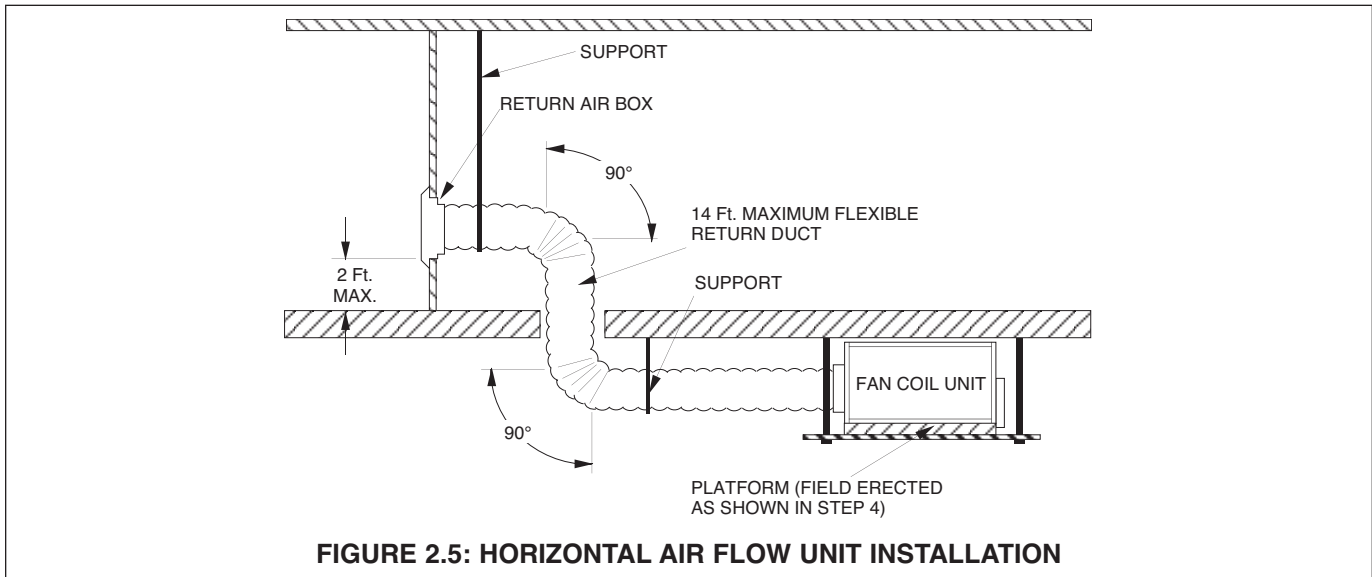
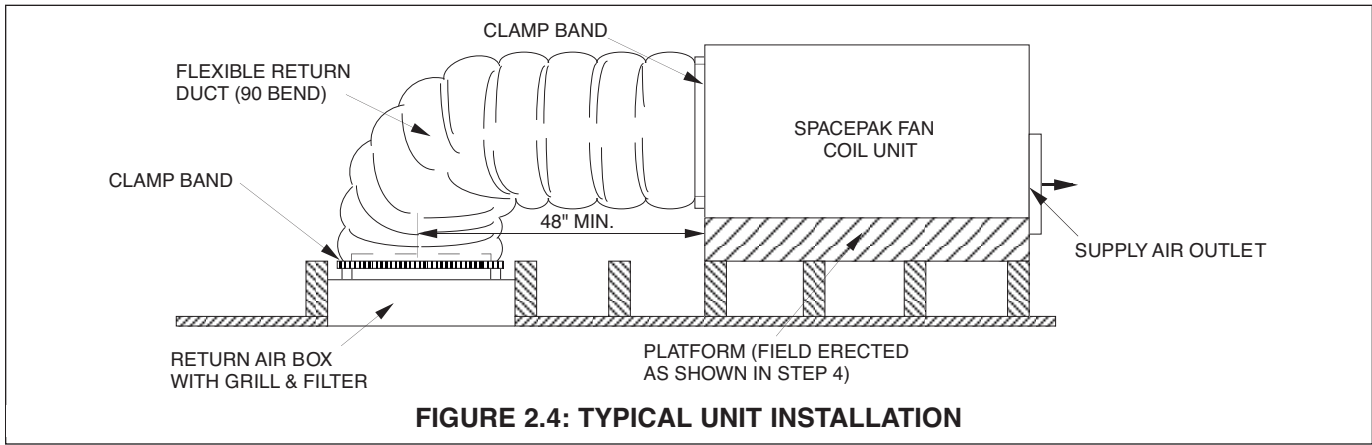

STEP 2: CUTTING RETURN AIR OPENING

Select exact location for return air box. Avoid installing box in dining room, living room, kitchen, etc., unless return air duct can be installed with at least two 90° bends (accomplished by splicing two return air ducts together.)

For attic installations to raise fan coil unit up through opening, cut return air opening 14-1/2" wide by the "A" dimension (Figure 2.6) of appropriate unit size. These openings will accommodate the return air box with sufficient frame lip to cover the opening (see Figure 2.6).

NOTICE: The return air adapter may need to be removed from the unit to fit through the opening cut out.

Refer to the "Installation Tip" supplied with the return air box.

If ceiling joists are on 16" centers, the 14-1/2" width of the return air box should fit between successive joists. Where joists run in the opposite direction, or to properly center the return, it may be necessary to cut joists and install headers.

For all wall return applications, cut the return air opening to accommodate the return air box (measure box itself). Remember, location of opening must allow for a 90° bend in the return air duct.

Check the opening for proper fit of the return air box. Do not install the return air box until the installation of the entire SpacePak system is completed, if you want to fit materials up through this hole.

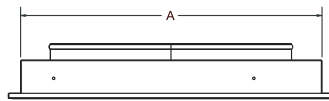

Measure return air box dimension "A" to determine length of opening.
Height = 14-5/16"

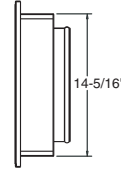
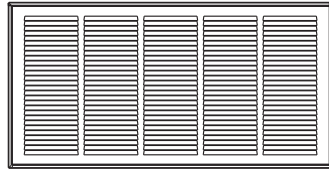

DWG0045

FIGURE 2.6: RETURN AIR BOX FRAME DIMENSIONS

STEP 3: ATTACHING SUPPLY AIR PLENUM ADAPTOR

NOTICE: If the unit is to be located in the attic and installed through the ceiling joists, attach the supply air plenum adaptor in the attic.

NOTICE: An Electric Heat Module cannot be installed in the WCSP-J model (due to resulting blower housing obstruction).

A. HORIZONTAL DISCHARGE:

Refer to Figure 2.7 and duct installation instructions supplied with fan coil unit.

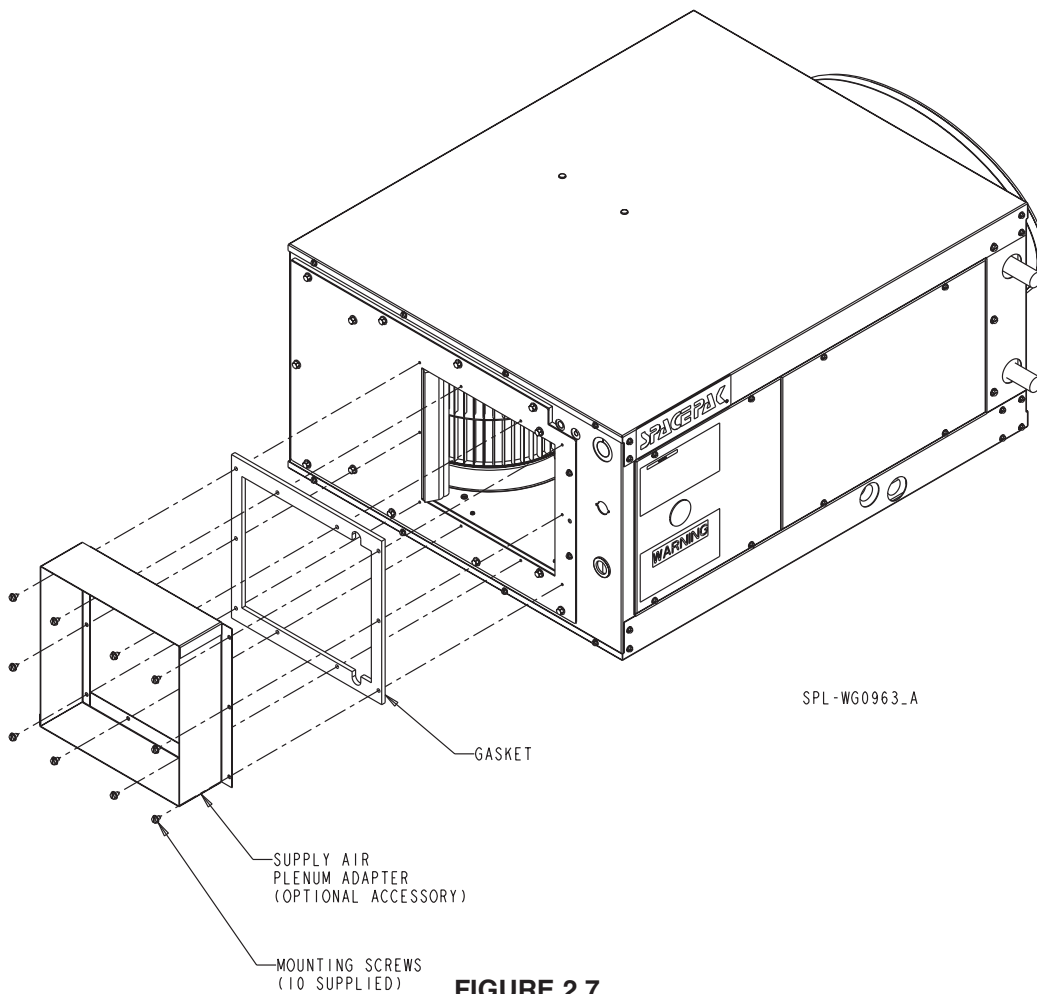

FIGURE 2.7

STEP 4: SETTING THE UNIT

Construct a platform for the fan coil unit, as shown in Figure 2.8. The platform can be constructed of 2 X 4 (minimum), 2 X 6, 2 X 8 and 2 X 10 lumber, as necessary to achieve sufficient height so that proper condensate drain line pitch of 1/4" per foot can be maintained. Figure 2.9 shows the approximate normal allowable run of condensate piping as a function of the framing lumber used for platform construction. The platform covering should be 1/2" plywood minimum.

Attach vibration isolation pads (supplied inside fan coil unit) to platform covering as shown in Fig. 2.8.

Secure the platform to the joist or floor, depending on location selected for the fan coil unit. Make sure platform is level.

For locations where the fan coil unit will be suspended, suspend platform from overhead by 1/4" threaded rods.

NOTICE: Leave room on sides for servicing.

For installations with a return air box and return air duct, set fan coil unit on the platform with the elliptical opening facing in the direction of the return air opening. The supply air plenum adaptor should overhang the platform. **DO NOT** let the adaptor support the weight of the unit.

Do not secure the unit to the platform, as the weight of the unit will hold it in position.

FIGURE 2.9: CONDENSATE PIPING RUNS

LUMBER SIZE	2 X 4	2 X 6	2 X 8	2 X 10
MAXIMUM HORIZONTAL	8'	16'	24'	32'

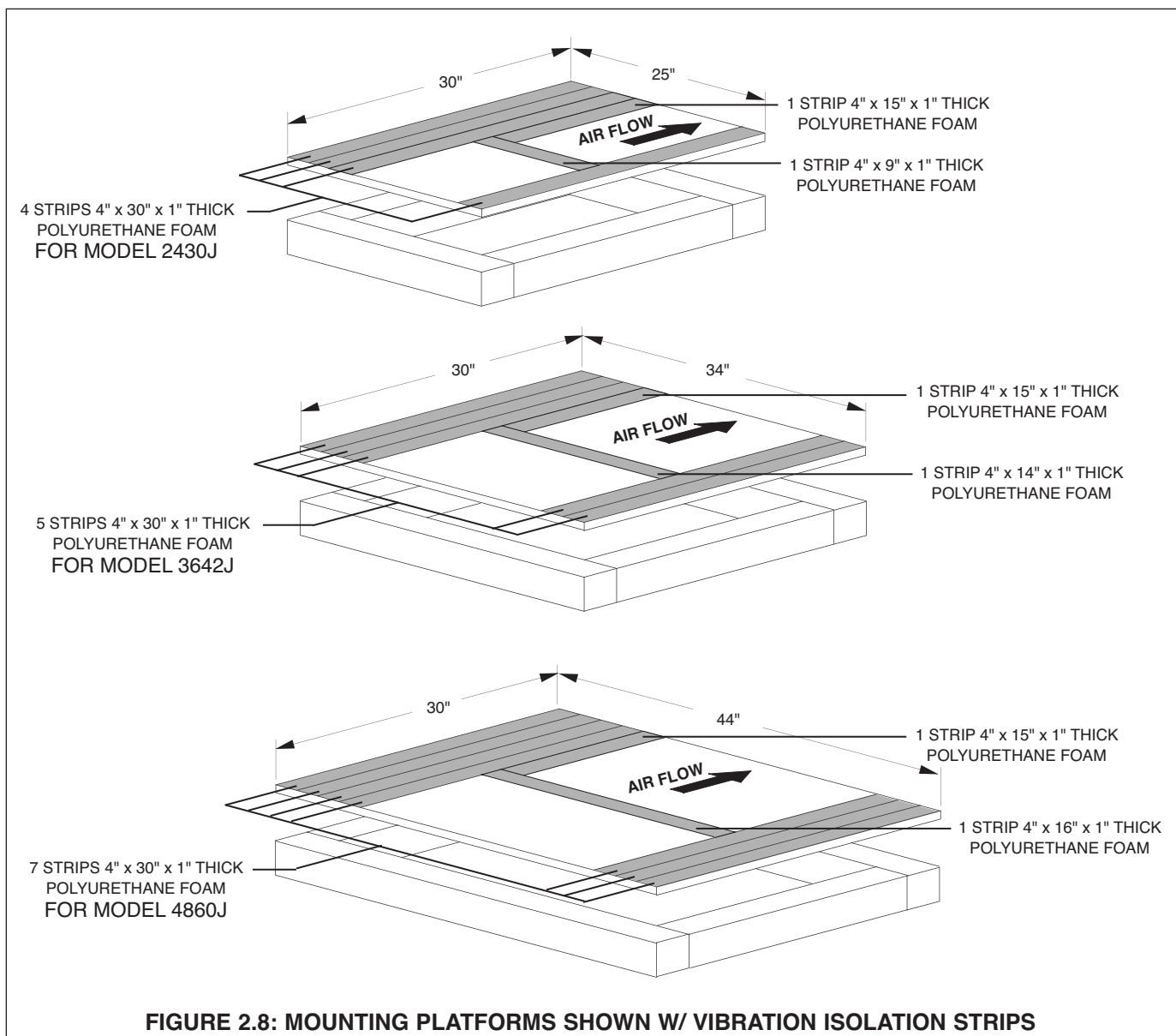

STEP 5: CONNECTING WATER LINES

Connect water lines from outdoor chiller unit to the fan coil unit in accordance with the chiller manufacturer's recommendations.

Step 6: Installing the Condensate Trap & Line

NOTICE: It is a requirement of the International Mechanical Code (307.2.3) to install a secondary drain or an auxiliary drain pan where damage to any building components will occur as a result of overflow from the equipment drain pan or stoppage in the condensate drain piping from a cooling or an evaporator coil. Follow local code requirements.

NOTICE: The secondary drain connection requires field supplied components to complete installation. Follow local code requirements.

NOTICE: Never connect condensate line to a closed drain system.

Refer to Fig. 2.2 for primary and secondary condensate drain locations. Components for the PVC condensate trap are provided in a separate bag with fan coil unit (see Fig. 2.10) and should be cemented together with PVC pipe cement.

▲ CAUTION Do not use substitute trap. Do not cut off or alter trap components.

Thread male adapter (see Fig. 2.10) into unit's primary condensate drain connection. Assemble and cement remaining components together. Then cement assembly to male adapter. The 45° elbow provides an offset from beneath unit suction line for access to clean-out plug.

Run a condensate line from the trap to a suitable drain that's in accordance with local codes. Make sure the line is pitched 1/4" per foot.

FIGURE 2.10: CONDENSATE TRAP ASSEMBLY

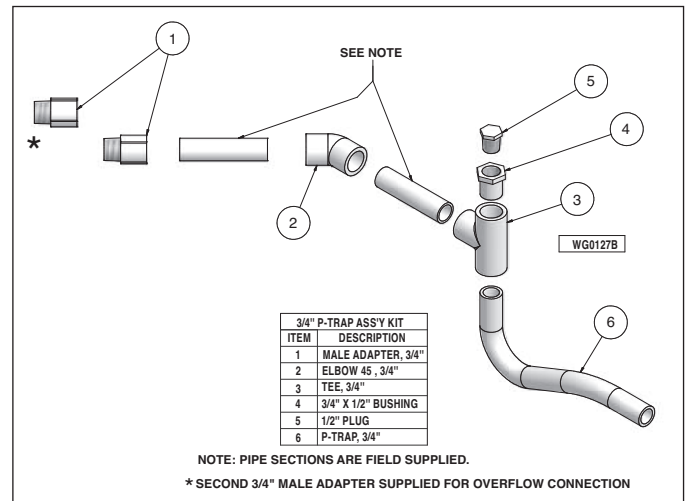

Step 7: Wiring the Unit

▲ WARNING Turn off electrical power supply before servicing. Contact with live electric components can cause shock or death.

All electrical and control wiring must be installed in accordance with the codes listed in Section 1 of this manual. Wiring diagram is provided in Figure 2.11. A separate 230/60/1 power supply is recommended for the unit. Use standard 15-amp circuit breaker and 14-gauge wire from power supply to unit.

Connect power supply to Terminals L1 and L2 on the high voltage terminal block. Connect a ground wire to the equipment ground terminal located next to the high voltage terminal block.

Locate the room thermostat on a wall near the return air box, between 40" to 48" from the floor. Connect the low-voltage thermostat wiring from the room thermostat to the low voltage control block in the unit.

Connect low voltage from air handler to condensing unit as shown in figure 2.11.

Set DIP switches according to application. See page 13, SpacePak J Series Control DIP switch settings.

Alternately, the unit may be configured to run on 115V, 60 Hz power. Refer to kit WG0858 for instructions and material to convert from 230V to 115V shipped with the unit.

FIGURE 2.11: MODEL WCSP-J 230V STANDARD WIRING SCHEMATIC*

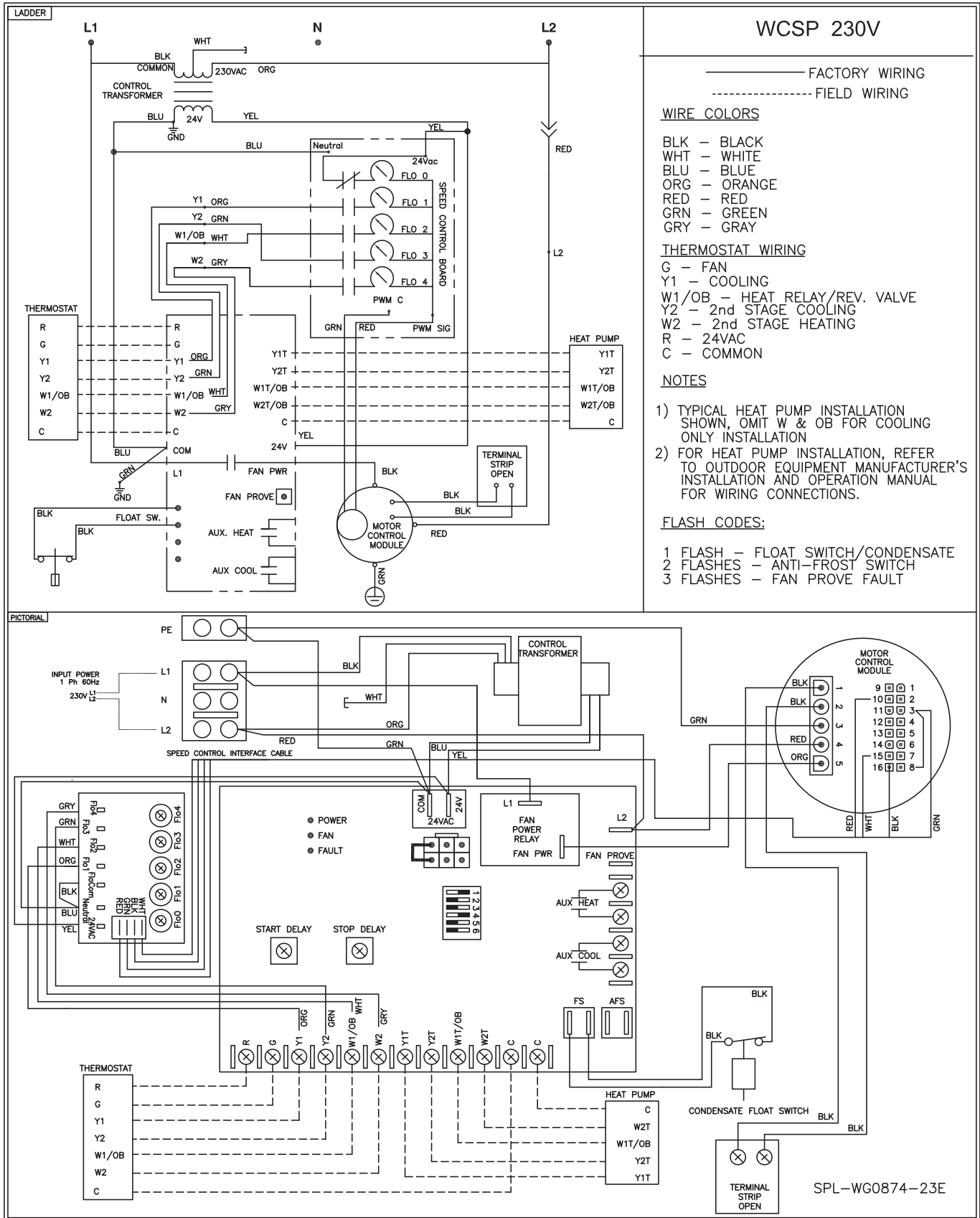

* For 115V conversion instructions see conversion kit supplied separately with the unit.

STEP 8: INSTALLING AIR DISTRIBUTION COMPONENTS

All plenum duct and supply tubing runs as well as room terminator locations must be in accordance with air distribution system requirements listed in Section 1 of this manual. Where taping of joints is required, UL181 approved tape is required.

Plenum Duct Installation

All tees, elbows and branch runs must be a minimum of 24" from the fan coil unit or any other tee, elbow or branch run. Keep all tees and elbows to a minimum to keep system pressure drop on larger layouts to a minimum.

NOTICE: Refer to duct installation instructions supplied with fan coil unit or follow manufacturers instructions supplied with other duct system types.

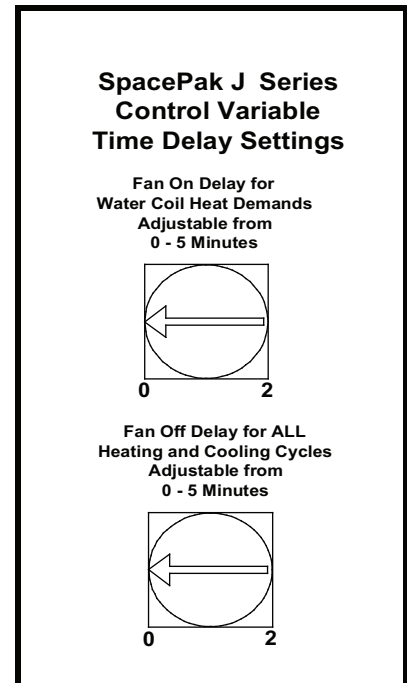
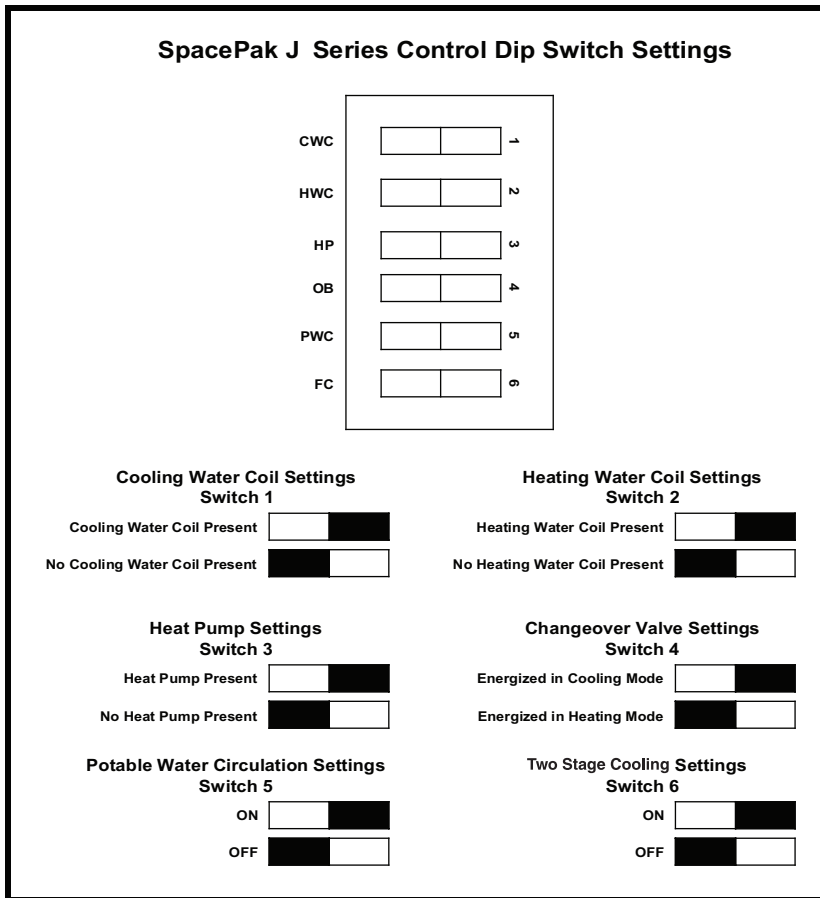

SpacePak J Series Control Indicator LEDs

Power Indicator

The Power indicator will blink to indicate that the control is operational.

Fan Prove Indicator

The Fan Prove indicator will illuminate when there is power to the fan and the optional damper is in the open position.

Note: The Fan Prove Terminal will also energize with 24VAC when the above conditions are met.

Fault Indicator

Fault Flash Codes:

Float Switch	1 Flash
Anti-Frost Switch	2 Flashes
Fan Prove Fault	3 Flashes

Note: All Flash Codes are latched until power is cycled, even if the fault is cleared. The Float Switch requires power to be cycled to resume operation.

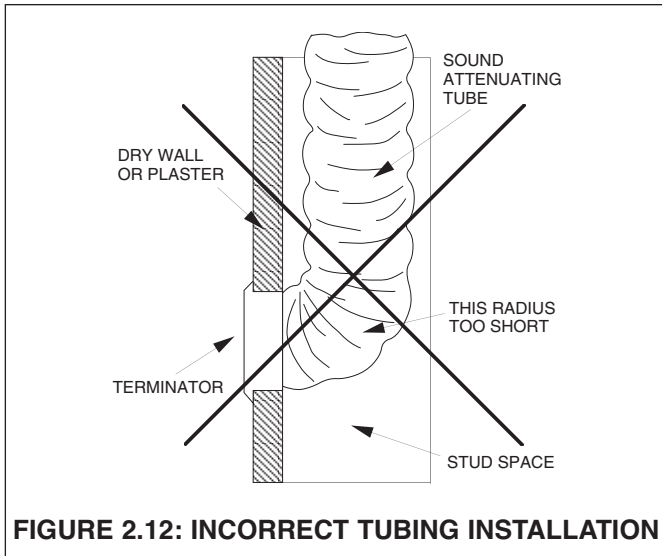

FIGURE 2.12: INCORRECT TUBING INSTALLATION

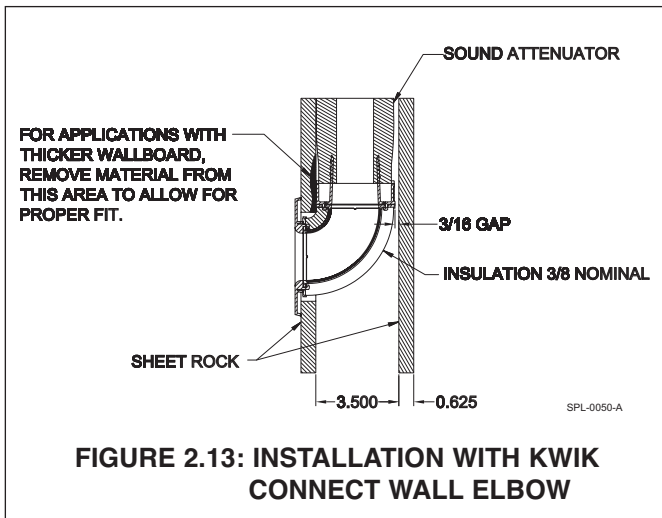

FIGURE 2.13: INSTALLATION WITH KWIK CONNECT WALL ELBOW

Room Terminator & Sound Attenuating Tubing Installation

Room terminators and pre-assembled sound attenuating tubes are provided in the Installation Kits.

NOTICE: Do not install terminators in a wall in which a sharp bend in the sound attenuating tube is required (see Figure 2.12). The result would be unacceptable noise.

OPTION: Using a SpacePak Kwik Connect Wall Elbow (Model Number: AC-KCWE) addresses this condition (see Figure 2.13).

In marking location for room terminator (see Figure 2.14), the center of the terminator should be 5" from the wall or, when installed in the corner of a room 5" from both walls.

After marking location, drill a 1/8" diameter hole for outlet. Verify there is at least a 2" clearance all around the 1/8" hole to receive tubing and connector. Adjust direction of hole as needed, to gain this 2" clearance. After all clearances have been checked, take a 4" diameter rotary-type hole saw and cut a hole, using the 1/8" diameter hole as a pilot.

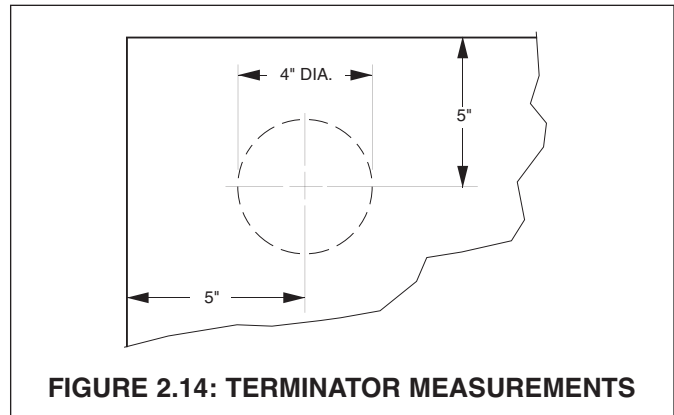

FIGURE 2.14: TERMINATOR MEASUREMENTS

Assemble spring clips to terminator plate with screws provided in installation kit. Tighten clips until they are close to the thickness of the material they are being mounted to.

Assemble the room terminator to the sound attenuating tubing by simply fitting the two pieces together and twisting until tight (see Figure 2.15). If the terminator is to be used in a floor location, then field fabricate a small screen (1-1/2" square; 1/4 x 1/4 20-gauge galvanized wire screen) and place screen over opening on the back of the terminator prior to twisting on the kwik-connect (on the sound attenuating tube).

NOTICE: Do not shorten sound attenuating tube length. The result would be unacceptable noise.

Push the free end of the sound attenuating tube through the 4" hole until the two toggle springs on the room terminator snap into place.

Center the two spring clips on a line parallel to the direction of the tubing routing from the room terminator (see Figure 2.15). This is important since the weight of the tubing will have a tendency to cause a part of the terminator to pull away from the ceiling if the clips and tubing do not run parallel.

Then tighten the screws (attached to the terminator) until the terminator is snug against the ceiling or floor. **Do not overtighten.** For installations with floors or ceilings which are thicker than normal, longer toggle screws or special mounting plates may be required.

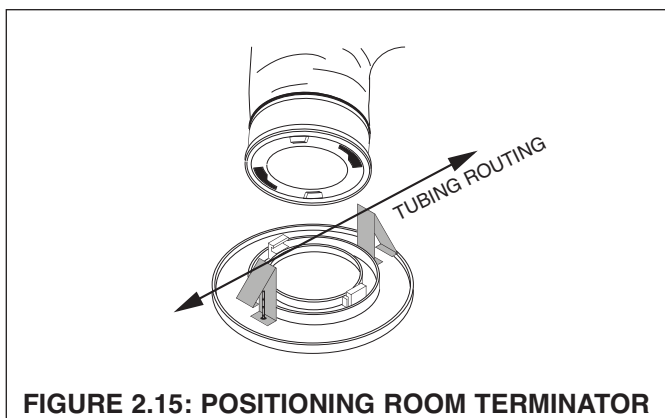

FIGURE 2.15: POSITIONING ROOM TERMINATOR

Supply Tubing Installation

Kwik-connects and balancing orifices are provided in the Installation Kits. Plenum take-offs, gaskets and fasteners are supplied in the separate plenum take-off kits.

Avoid sharp bends in the supply tubing (as well as the sound attenuating tube). The minimum radius bend is 4" (see Figure 2.16); however, wherever possible, hold to a larger radius.

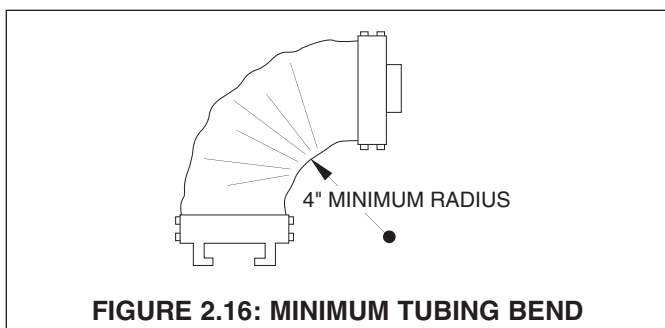

FIGURE 2.16: MINIMUM TUBING BEND

At the plenum, all supply tubing connections must be a minimum of 18" from any plenum tee, plenum elbow or the fan coil unit.

Individual supply tubing runs **must be a minimum of 6-feet**, even if the distance between the sound attenuating tubing and plenum is less than 6 feet.

Supply tubing comes in 100-foot sections (R8 tubing comes in 75-foot sections and R6 tubing comes in 100-foot sections) and may be cut to length with a knife or fine tooth hacksaw.

For each supply tubing run, estimate and cut the length of tubing that will be needed between the plenum and sound attenuating tube. At the open end of the supply tubing a kwik-connect will be installed (see Figure 2.17). First, push back the cover and the insulation exposing approximately 4" of the inner core. Fold in any tails or frays that may be present after cutting the supply tubing. Second, hand compress the corrugations until they are densely compacted 1-1/2" to 2" from the open end of the supply tube. Third, thread kwik-connect into the inner core until snug. Fourth, pull the insulation and cover forward and tuck it into the deep groove on the back side of the kwik-connect. Fifth, wrap the connection securely with UL181 approved tape.

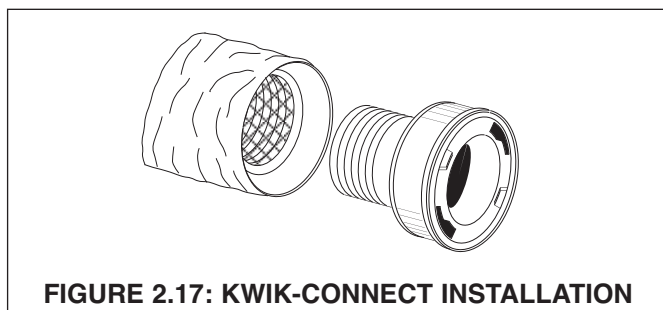

FIGURE 2.17: KWIK-CONNECT INSTALLATION

When finished, simply twist together (see Figure 2.18) the kwik-connect on the sound attenuating tube, and wrap the connection securely with tape.

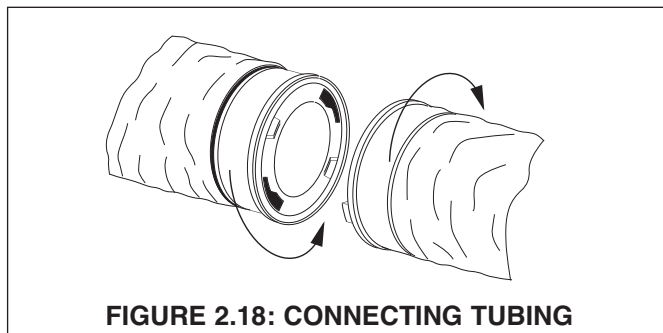

FIGURE 2.18: CONNECTING TUBING

After attaching the supply tubing to the sound attenuating tube, bring the open end of the tubing to the plenum.

To cut a hole in the plenum, refer to duct installation instructions supplied with fan coil unit. Sheet metal duct requires a 2-1/16" hole.

Remove the hole cut-out from the plenum. Make sure there is no "flap" left inside plenum that could block hole during operation.

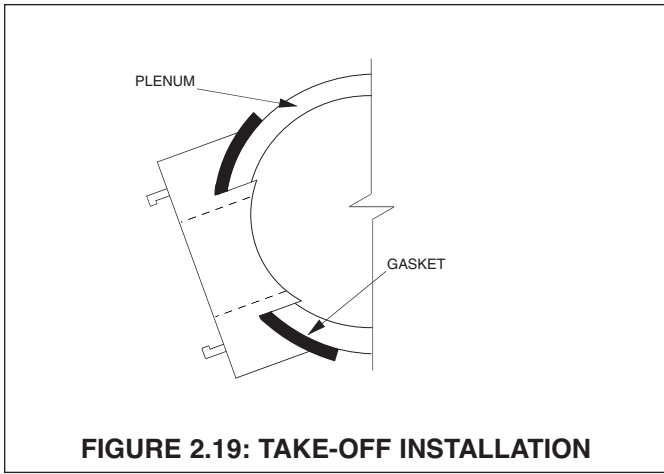

FIGURE 2.19: TAKE-OFF INSTALLATION

Place the plenum take-off gasket on the back side of the plenum take-off and insert the assembly into the hole in the plenum (see Figure 2.19).

NOTICE: Gasket must be installed to seal plenum take-off to prevent air leakage.

Orient the plenum take-off to match the curvature of the plenum duct. Hand insert the four plenum take off fasteners one at a time such that each clip reaches the interior of the duct. Using the SpacePak pliers, snap the fasteners into place until they lock in place (see Figure 2.20).

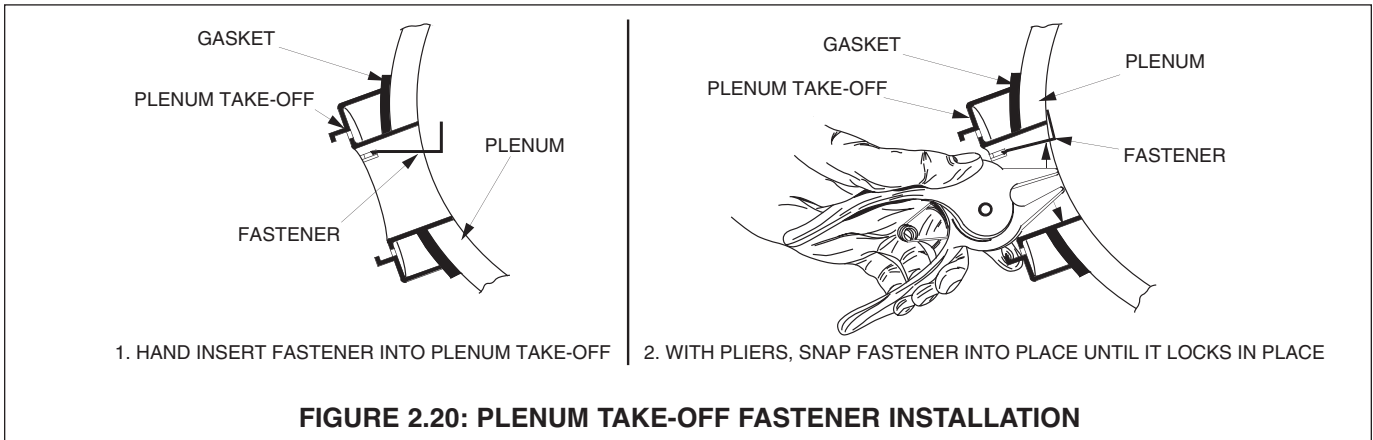

FIGURE 2.20: PLENUM TAKE-OFF FASTENER INSTALLATION

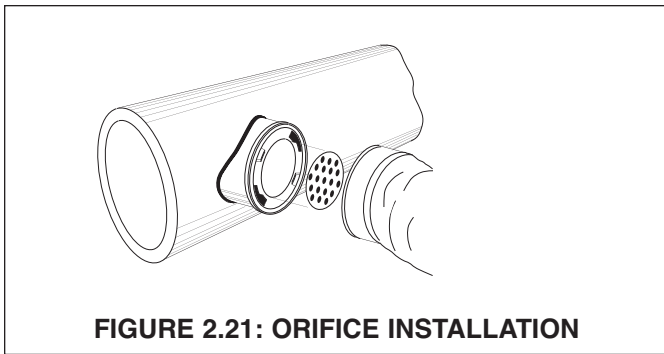

FIGURE 2.21: ORIFICE INSTALLATION

NOTICE: All four fasteners must be installed to assure air tight fitting between plenum take-off and plenum.

In accordance with your calculations as to requirements for balancing orifices, mount the orifice in the outlet of the plenum take-off (see Figure 2.21), prior to attaching the supply tubing.

Next, install a kwik-connect in the open end of the supply tubing, using the same procedures as before, and twist together kwik-connects on supply tubing and plenum take-off. Wrap connection securely with tape.

Return Air Box & Duct Installation

Remove the return air grill from the return air box and remove the air filter from the return air grill.

Insert the return box from below for ceiling installation (or from the front for wall installations) and fasten with four screws through holes provided on the long side of the box. (see Figure 2.22).

Then, insert return air grill into box (see Figure 2.22) and fasten with the four screws provided through the holes on both sides. Open return air grill (turn the ¼ turn latches) and insert filter. Close the return air grill. Slide a clamp band (provided with return air box) over one end of the return air duct. Place that end over the elliptical flange on the fan coil unit (see Figure 2.23). Move the clamp over the flange and tighten so the clamp holds the return air duct securely to the flange.

Follow the same procedures to attach the return air duct to the return air box (see Figure 2.23).

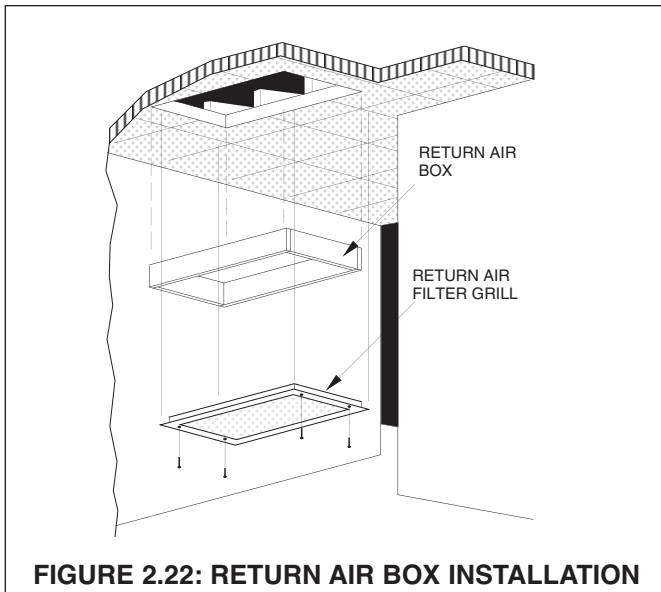

Step 9: B & C Series Unit Retrofits

For retrofitting an ESP-J series unit to an existing ESP-B or C series, some modifications will need to be made to the current system. The necessary changes are below and the extent of the changes is dependent upon the model of the unit. (Refer to Figures 2.25 / 2.26 / 2.27)

ESP-2430 Retrofits

The 7" duct can still be utilized with a transition kit (Part No. BM-6918) available from SpacePak. This kit will reduce the main plenum from 9" to 7" to adapt to the existing 7" duct.

ESP-3642/4860 Retrofits

The existing plenum duct, which is typically 7", will need to be replaced with 8" X 8" duct board or field supplied 9" round duct. The return duct and return grille will also

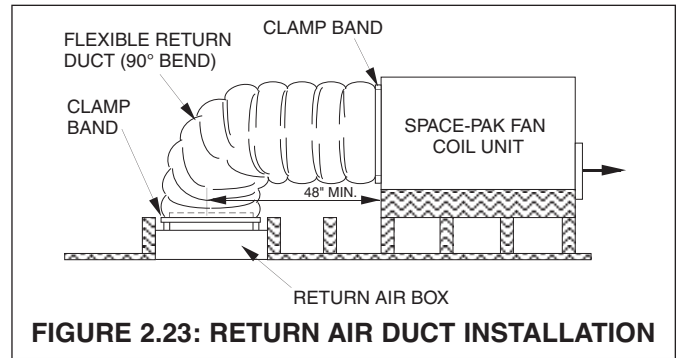

Winter Supply Shut-Off Installation

Simply insert winter supply shut-offs into the room terminator openings (see Figure 2.24). Wrap the return air filter in a plastic bag and reinstall it to block the return air opening. Winter supply shut-offs prevent moisture from collecting in ductwork during winter months. Be sure to remove the plastic bag and all winter supply shut-offs before operating the system.

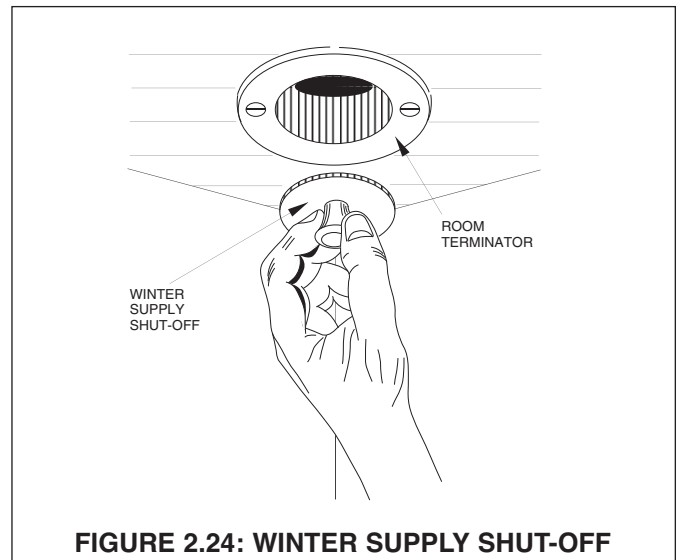

have to be replaced with the proper parts for the replacement model. The reason for this change is the amount of air supplied by current models is 30% higher than the B & C Series models. The existing 7" duct work will reduce the air flow and cause excessive static pressures resulting in lack of performance and could possibly freeze up the coil which will result in compressor failure due to short cycling.

NOTICE FOR ALL RETROFITS

It may be necessary to add outlets to the system. The number of additional outlets will be dependent upon the external static pressure which should be measured with a manometer. This measurement should be between 1.2-1.5" WC. For more details on this test procedure and location for the test, refer to the System Start Up and Adjustment section in this installation manual.

FIGURE 2.25: STRAIGHT DUCT OR SHOTGUN LAYOUT

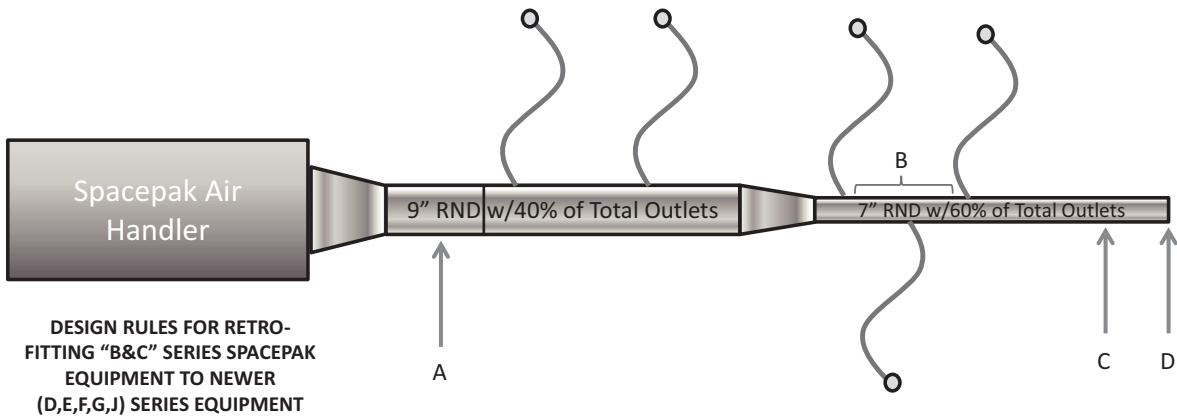

- A: No outlets in the first 18" of straight pipe coming off the Air Handler
- B: Minimum distance between outlets is 6" on center
- C: Minimum distance when placing an outlet from end cap is 12"
- D: NEVER place an outlet in the End Cap

FIGURE 2.26: HORSESHOE LAYOUT

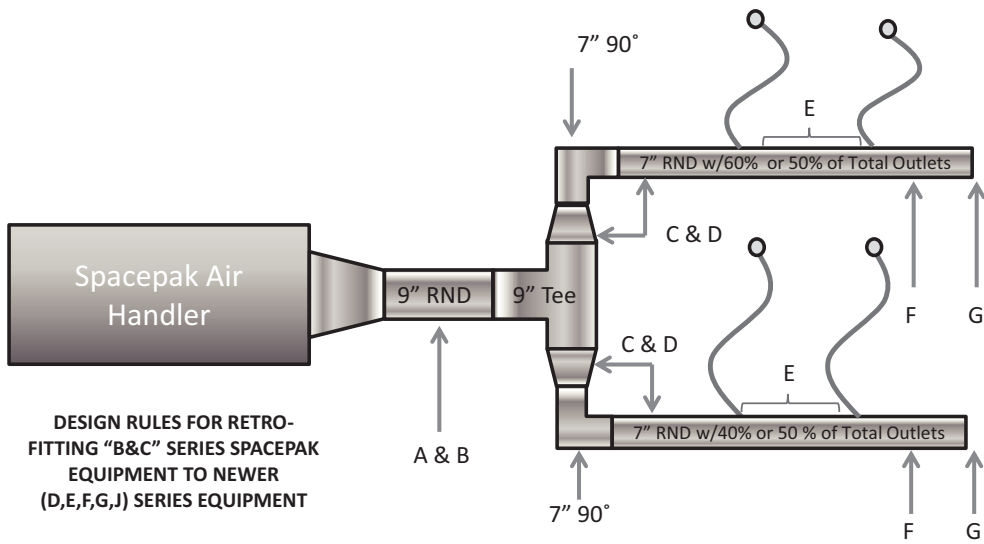

- A: Minimum distance from the air handler outlet to first tee or elbow is 18"
- B: No outlets in the first 18" of straight pipe off of the air handler
- C: Minimum distance of straight pipe after any tee or elbow is 18"
- D: Minimum distance when placing outlet after any tee or elbow is 18"
- E: Minimum distance between outlets is 6" on center
- F: Minimum distance when placing an outlet from the end cap is 12"
- G: Never place an outlet in the end cap

FIGURE 2.27: SIDE BRANCH

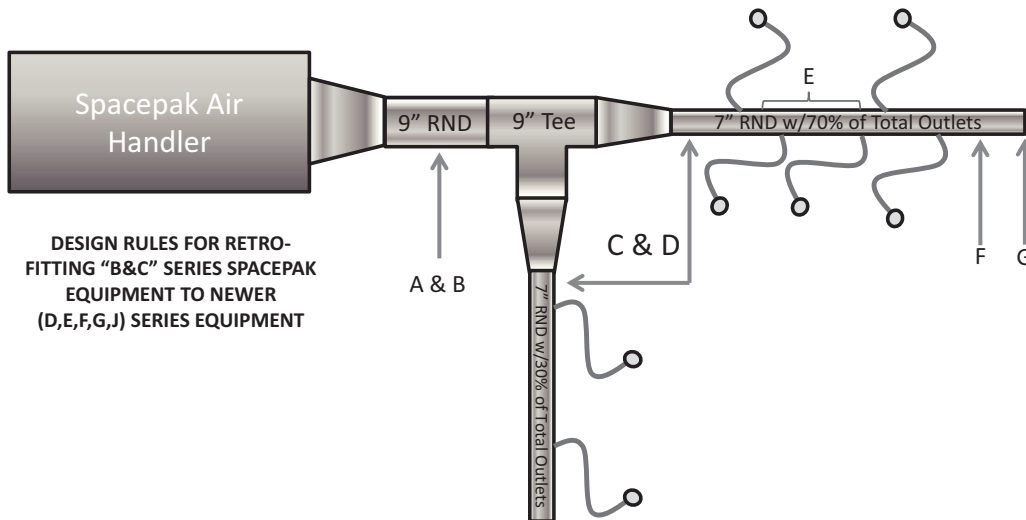

DESIGN RULES FOR RETRO-FITTING "B&C" SERIES SPACEPAK EQUIPMENT TO NEWER (D,E,F,G,J) SERIES EQUIPMENT

- A: Minimum distance from the air handler outlet to first tee or elbow is 18"
- B: No outlets in the first 18" of straight pipe off of the air handler
- C: Minimum distance of straight pipe after any tee or elbow is 18"
- D: Minimum distance when placing outlet after any tee or elbow is 18"
- E: Minimum distance between outlets is 6" on center
- F: Minimum distance when placing an outlet from the end cap is 12"
- G: Never place an outlet in the end cap

SECTION 3: START-UP & OPERATION

SEQUENCE OF OPERATION

When power is turned on and thermostat fan switch is set to ON and the cooling indicator is set to OFF, the indoor fan motor is energized through the normally open contact FR-1 of the FR fan relay in about 30 seconds. The outdoor unit is off.

When power is turned on and thermostat fan switch is set to ON or AUTO and the cooling indicator to COOL the indoor and outdoor units will start through the normally open contacts FR-1 and FR-2 of the FR fan relay.

The fan coil unit is equipped with a primary float switch, the outdoor unit will automatically shut down if the drain pan is full of water (condensate) and not draining. The fan coil unit will continue to operate, when the water level in the drain pan drops, the system will continue normal operation.

PRIOR TO START-UP

1. Check all electrical connections for tightness.
2. Check air filter has been installed in return air box or filter box.
3. Remove all winter supply shut-offs and store them in a safe place.

SYSTEM START-UP & ADJUSTMENTS

1. Place thermostat fan switch in ON position and cooling indicator in OFF position. In about 2 minutes, indoor unit blower will start.
2. Check blower operation for excess noise or vibration.
3. Check entire distribution system for leakage and apply additional tape where necessary.
4. Measure/adjust blower voltage/speeds
 - a. Remove the control box cover located on the side of the unit.
 - b. With the unit powered and operating from a conventional thermostat, ensure there is no conditioning call (Thermostat is satisfied) and switch the fan control to "Manual" or "On" to create a G call.

NOTE: IF NO AIRFLOW DURING W OR Y CALL, POTENTIOMETER MAY BE IN "OFF" POSITION. TURN CW TO ACHIEVE AIRFLOW

- c. Place the ground/neutral probe in the lower right hole marked "COM" and the volt probe in the hole marked "Flo0" (for fan only, G call) and measure DC volts between 0 and 5V. Adjust the potentiometer adjacent to the "Flo0" to achieve the desired volt reading. Repeat for remaining adjustments marked Flo1 through Flo4 as indicated on the label inside the cover. (Refer to Figure 3)

d. To determine unit airflow, in CFM, measure the voltage corresponding to the current conditioning call, and measure the external static pressure in the plenum, at least 18" from the unit or nearest transition point. Locate the static pressure on the left side of the charts (Figure 3.2/3.3/3.4) and read across until you reach the curve corresponding to the measured voltage. From the point where this crosses, drop a line straight down to read the airflow at the bottom of the chart. For system settings of 1.2" static pressure, refer to tables in Figures 3.21, 3.31 and 3.41.

e. To adjust airflow, locate the nearest system curve, and follow parallel to this curve while adjusting the signal voltage to achieve the desired airflow. If the static pressure falls above or below the desired operating range for the given airflow, then the air delivery system must be adjusted. To lower static pressure, provide additional outlets to the system, to raise the static pressure, install restrictor orifices as described in the Installation and Operations Manual.

f. Replace the speed control cover.

5. Check that system static pressure is within acceptable limits (minimum 1.2" WC - , maximum 1.5" WC). You can use a U-tube manometer to check the external static pressure on the duct system.

1. Puncture a 1/4" diameter hole in the plenum duct at least 18" from the fan coil unit.

2. Insert the high-side manometer tube into the hole so that the end is approximately flush with the inside wall of the plenum, and perpendicular to the direction of airflow.

3. System static pressure should be between 1.2" and 1.5" WC.

a. If the pressure is higher than 1.5" provide additional supply runs to increase airflow or lower the fan speed by turning the fan speed adjustment for the current mode of operation counter-clockwise to reduce the static pressure.

b. If the pressure is lower than 1.2", look for leaks in the supply plenum, restrictions in the return system (including clogged filters) If more than the recommended number of supply runs are installed, you may install flow restrictors (orifices) in these runs. If the number of runs is appropriate for the load, increase the static pressure by turning fan speed adjustment for the current mode of operation clockwise to increase the static pressure.

6. Check that blower motor amp draw compares with fan coil unit rating plate. Amp draw shown on plate is the FLA of motor (not the actual running amps) and will vary with the pressure and voltage.

7. Place the thermostat cooling indicator in COOL position, which will start the outdoor unit. Let the system run at least 30 minutes to stabilize operating conditions.

8. For outdoor unit start-up, follow manufacturer's instructions.

9. Check that temperature drop across the water coil in the indoor unit is between 20°F to 28°F.

10. Check the chiller or boiler for proper operation according to the manufacturer's instructions.

FIGURE 3: SPEED CONTROL PANEL

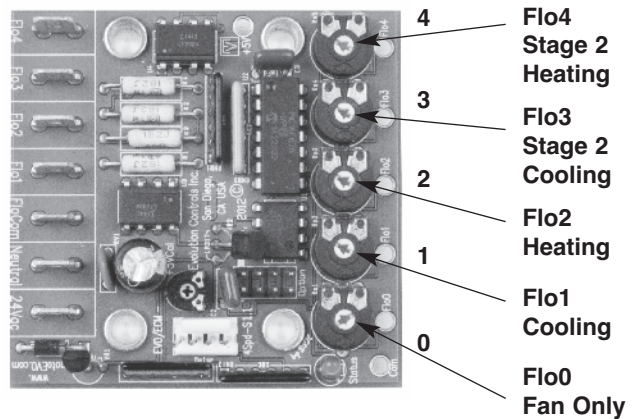
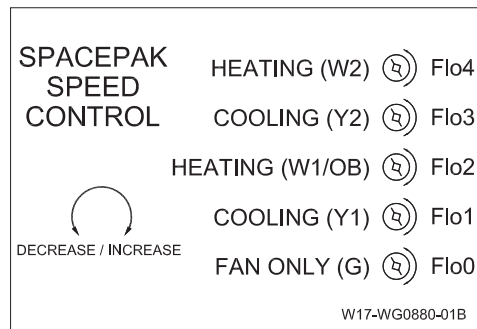

OPERATING SETPOINTS - 2430J

FIGURE 3.2

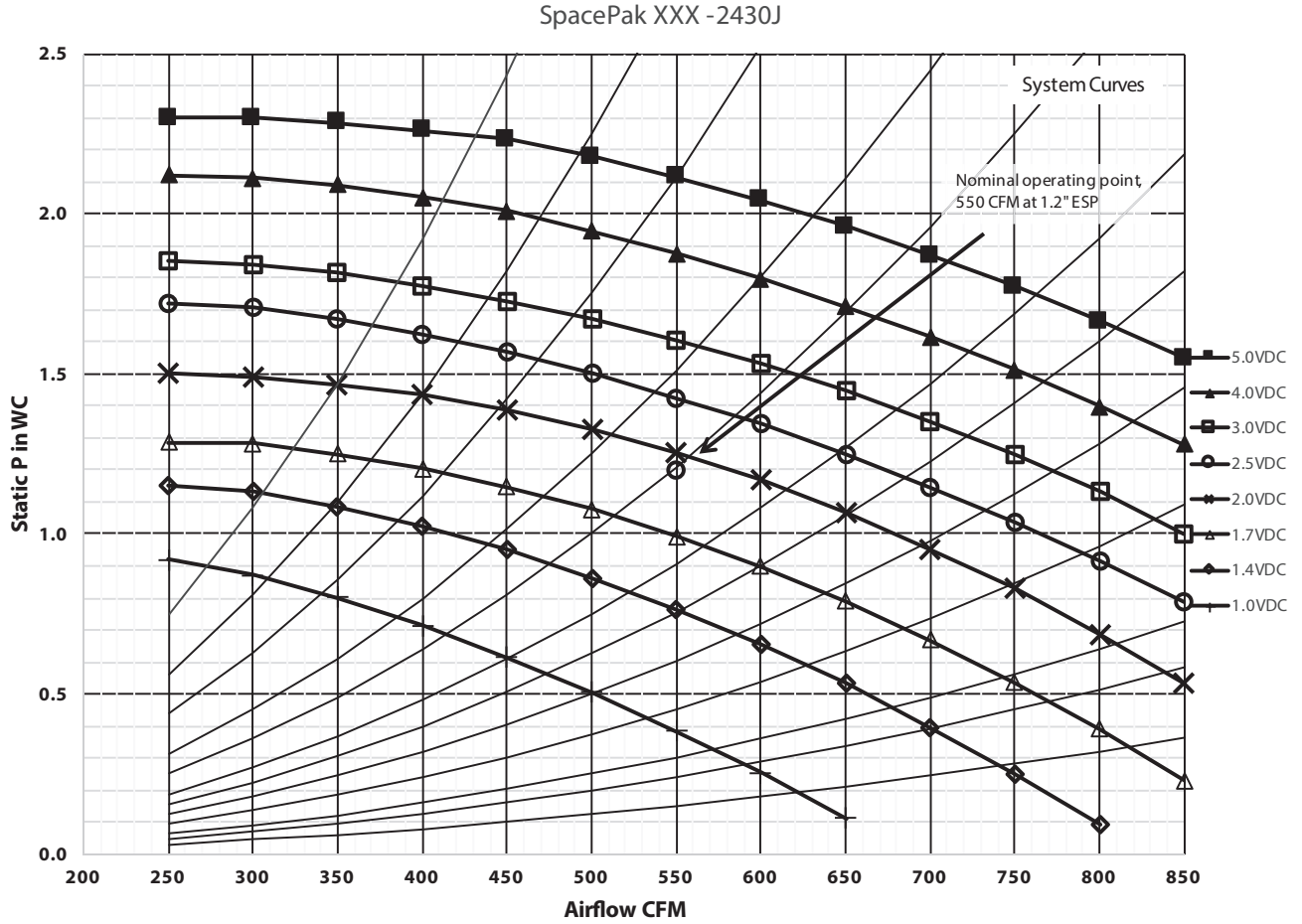

FIGURE 3.21

Static P "WC	CFM's @ Speed Control Setting (VDC) -2430								
	5.0V	4.5V	4.0V	3.5V	3.0V	2.5V	2.0V	1.5V	1.0V
2.2	475	380							
2.0	638	547	455	260					
1.8	680	640	600	485	370				
1.6	830	770	710	633	555	420			
1.5		815	755	693	630	500	250		
1.4			800	735	670	565	440		
1.2				825	770	688	580	300	
1.0					850	765	680	460	
0.8						850	760	555	350
0.6							830	650	460

OPERATING SETPOINTS - 3642J

FIGURE 3.3

SpacePak XXX -3642J

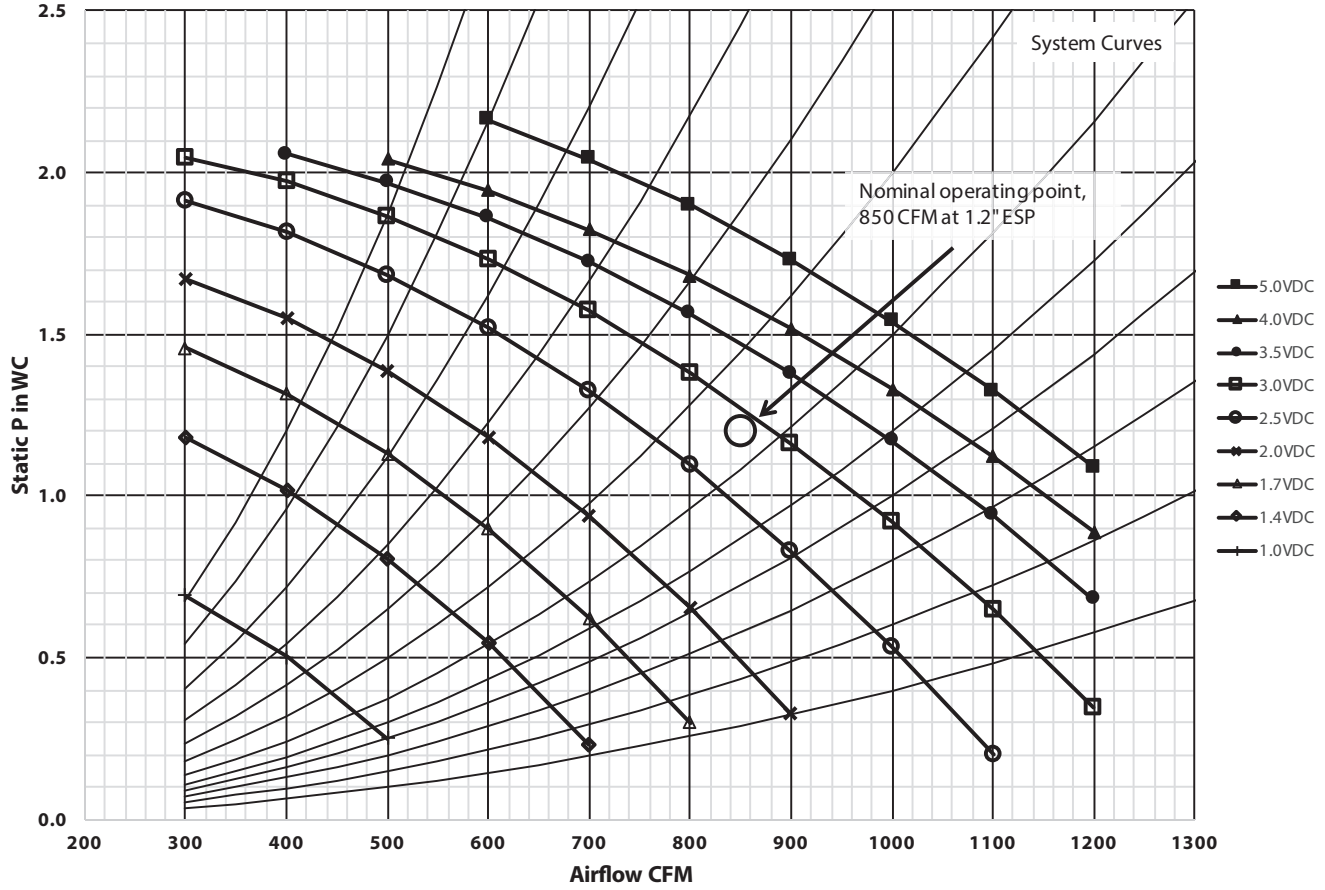

FIGURE 3.31

Static P "WC	CFM's @ Speed Control Setting (VDC) -3642								
	5.0V	4.5V	4.0V	3.5V	3.0V	2.5V	2.0V	1.5V	1.0V
2.2	520								
2.0	730	635	540	460	380				
1.8	860	795	730	640	550	410			
1.6	970	910	850	800	695	550	360		
1.5	1,020	965	910	830	740	610	430		
1.4	1,060	1,010	960	890	790	680	490		
1.2	1,150	1,095	1,040	980	880	755	590	340	
1.0	1,230	1,190	1,150	1,095	985	840	680	450	
0.8	1,280	1,260	1,240	1,150	1,080	915	750	580	
0.6	1,310	1,295	1,280	1,230	1,180	980	820	630	300

OPERATING SETPOINTS - 4860J

FIGURE 3.4

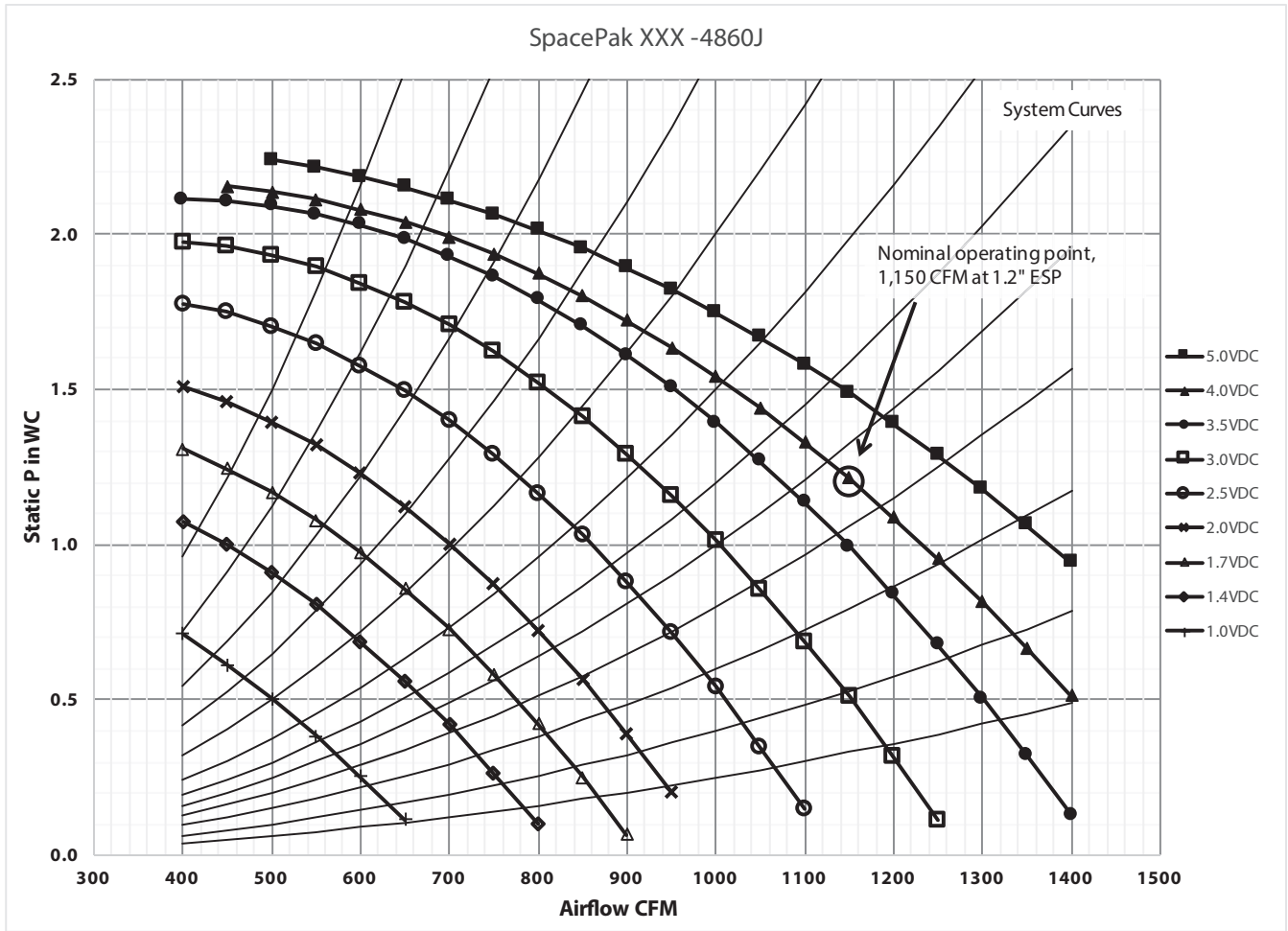

FIGURE 3.41

Static P "WC	CFM's @ Speed Control Setting (VDC) -4860								
	5.0V	4.5V	4.0V	3.5V	3.0V	2.5V	2.0V	1.5V	1.0V
2.2	520								
2.0	760	728	695	625					
1.8	920	885	850	800	630				
1.6	1,040	1,005	970	900	760	585			
1.5	1,100	1,060	1,020	950	810	650	400		
1.4	1,145	1,108	1,070	1,000	860	700	500		
1.2	1,240	1,195	1,150	1,080	940	785	640		
1.0	1,325	1,280	1,235	1,140	1,005	860	705	500	
0.8	1,410	1,355	1,300	1,215	1,070	925	775	590	300
0.6	1,470	1,420	1,370	1,275	1,120	985	840	675	450

COMMON START-UP CONDITIONS

	CONDITION	VERIFICATION	SOLUTION
A.	Lack of cooling	1. Chilled water loop temperature	1. Adjust water temperature in chilled water loop
B.	Lack of heating	1. Hot water loop temperature	1. Adjust water temperature in hot water loop
C.	Blows cold air on initial start-up	1. Fan is controlled by a thermostat 2. Fan is controlled by an aquastat	1. Install aquastat 2. Adjust setting to allow water loop to reach proper temperature
D.	Condensate does not drain properly	1. Unit is not level 2. Unit is not trapped 3. Drain line is blocked	1. Make sure unit is level 2. Install trap supplied with unit 3. Clear blockage
E.	Unit sweats inside	1. Insulated panels not secured cabinet	1. Secure and seal all insulated panels to prevent air infiltration

FACTORS AFFECTING THE BALANCE OF THE SYSTEM

A. Room Terminators (Outlets): Based on the equipment selected, determine the recommended number of fully open outlets from Figure 3.1.

FIGURE 3.1

NOMINAL TONNAGE	MINIMUM RECOMMENDED NUMBER OF FULLY OPEN OUTLETS		
	MODEL	A	B
2	WCSP-2430J	12	14
2 1/2	WCSP-2430J	15	18
3	WCSP-3642J	18	21
3 1/2	WCSP-3642J	21	25
4	WCSP-4860J	26	28
5	WCSP-4860J	30	35

1. The minimum or recommended number of outlets means fully open outlets. Any outlet having an orifice would be only a percentage of an outlet.
2. For systems with average supply tubing lengths of 15 feet or less, use column A. For systems with supply tubing lengths greater than 15 feet, use column B.

NOTICE: The number of outlets and average length of the supply tubing has a significant effect on the overall system performance. It is highly recommended that the adjustment factors outlined in the SpacePak Application Manual are accounted for prior to any installation.

B. Orifice Combinations: Should orifices be required to balance the system (installed at plenum take-off), refer to the combinations listed in Figure 3.2.

FIGURE 3.2

DESIRED NUMBER OF TERMINALS *	TERMINAL - ORIFICE COMBINATION
.5	(1) .5
.65	(1) .35
.85	(1) .15
1.00	(1)
1.15	(1) .5 + (1) .35
1.30	(2) .35
1.50	(1) .35 + (1) .15 or (1) + (1) .5 or (3) .5
1.65	(1) + (1) .35 or (2) .5 + (1) .35
1.70	(2) .15
1.80	(2) .35 + (1) .5
1.85	(1) + (1) .15
1.95	(3) .35
2.00	(2)

* For a room with more than two (2) terminals, combinations of the above may be used to achieve the desired fractional number.

C. Supply Tubing Length: An outlet with a supply tubing length of 15 feet is considered one, fully opened outlet. For other lengths refer to Figure 3.3 for adjustment factors.

FIGURE 3.3

2" SUPPLY TUBING LENGTH ADJUSTMENT FACTOR CHART								
RUN	6'	8'	10'	12'	15'	20'	25'	30'
FACTOR	1.18	1.14	1.11	1.06	1.0	.9	.8	.66

SECTION 4: MAINTENANCE

The SpacePak system has been designed to provide years of trouble-free performance in normal installations. Examination by the homeowner at the beginning of each cooling season, and in mid-season should assure continued, good performance. In addition, the system should be examined by a qualified service professional at least once every year.

YEARLY MAINTENANCE CHECKLIST

1. Check and clean air filter. The air filter is permanent type. Remove and clean thoroughly with soap solution and water.

▲ WARNING Turn off electrical power supply before servicing. Contact with live electric components can cause shock or death.

2. Check fan coil unit. Turn off unit power disconnect switch and remove service access panels.

a. Inspect coil and blower wheel for build-up of dust and dirt. Clean with solvent and/ or water as necessary.

b. Replace service access panels and turn on unit power disconnect switch.

3. Check that unit condensate drain is clear and free running, and plug is in cleanout.

4. For chiller or boiler unit, follow manufacturer's maintenance instructions.

5. Follow "System Start-Up & Adjustments" procedures in Section 3 of this manual.

IF SYSTEM FAILS TO OPERATE

1. Check that thermostat switch is set for proper mode of operation and is set below room temperature.

2. Check that chiller or boiler unit is operating.

3. Check for tripped circuit breaker or blown fuse at the main fuse box. Reset breaker or replace blown-fuse with same size and type.



Service / Troubleshooting FORM "1A"

Customer / Dealer Data:

Name: _____

Address: _____

Tel (day) _____ (Mobile) _____

Installing Dealer / Contractor:

Name: _____

Tel: _____

Equipment Data:

SPACEPAK Model # ESP / WCSP - _____

SPACEPAK Serial # _____

SPACEPAK Date of Installation: _____

Cond Unit Mfr: _____

Cond Unit Mod #: _____

Rated Capacity: _____ BTUH; SEER: _____

Air-side Data:

Total # of outlets: _____; Supply tube length: _____ Ft (avg)
(Please sketch duct layout on reverse side of this sheet, noting all fittings and distances, including return duct size/length)

Air Filter: Size (LxHxD) _____

Type (pleated, etc): _____

Is the filter clean? _____ (Y/N)

Static Pressure (Ps) in supply plenum: _____ "WG
(Measure at approximately 3 ft downstream of blower discharge)

Ps in return duct (downstream of filter, upstream of coil) _____ "WG

SpacePak Motor: Amps (measured): _____ Amps

Voltage (measured): _____ Volts

Air Temperatures:

@ Return (indoor ambient): _____ °FDB; _____ °FWB

@ Condensing unit (outdoor ambient): _____ °F

@ AHU (read 3 ft from fan discharge) _____ °F

@ last supply outlet _____ °F

Refrigeration-Side Data:

Line sizes: Liquid _____ Suction _____

Total equivalent length of lines: _____ Ft; Vertical Rise: _____ Ft.

@ Condensing Unit:

Liquid: _____ psi; Temp: _____ °F; Subcool: _____ °F

Suction: _____ psi; Temp: _____ °F; Superheat: _____ °F

@SpacePak:

Liquid: _____ psi; Temp: _____ °F; Subcool: _____ °F

Suction: _____ psi; Temp: _____ °F; Superheat: _____ °F

Approximate time running before taking readings: _____ Hrs.

Did you adjust the TXV? _____ (Y/N); (If yes, explain):

Refrigerant Charge (if weighed-in): _____ lbs

R410a / R22 (circle one)

Installed options: (circle one)

sight glass filter/drier zone controls

Other: _____

Water Data: (where applicable)

Line sizes: _____ "; Length: _____ FT

Water temperatures:

Supply: _____ °F; Return _____ °F

Glycol?: _____ (Y/N); % Solution: _____

NOTES: _____

REF. NO.	PART DESCRIPTION	UNIT SIZE	PART NUMBER
2	Primary Drain Pan	2430J	W06RWG0220-12
	Primary Drain Pan	3642J	W06RWG0220-13
	Primary Drain Pan	4860J	W06RWG0220-14
3	Coil Assembly, Hydronic	2430J	45W50-WG0631-01
	Coil Assembly, Hydronic	3642J	45W50-WG0631-02
	Coil Assembly, Hydronic	4860J	45W50-WG0631-03
5	Transformer Assembly	All Sizes	460RWG0604-J1
6	Blower Assembly	All Sizes	W35RWG0802-01
7	Terminal Block (High Volt)	All Sizes	W09RWG0422-01
8	Electrical Control Box Cover	All Sizes	462RWG0529-J1
9	Side Access Panel (Coil Side)	All Sizes	462RWG0527-01
10	Primary Float Switch	All Sizes	455RWG0543-02
11	Cable Connector, (Ground)	All Sizes	W09RWG0313-01
12	Control Board	All Sizes	W11RWG0478-01
13	EVO-ECM Speed Control Board	All Sizes	W11RWG0806-01
14	Cable, EVO-ECM Control	All Sizes	W11RWG0807-01
15	Speed Control Harness Assy	All Sizes	460RWG0811-J1
16	Motor Control Harness Assy	All Sizes	460RWG0844-J1
17	Voltage Select Terminal Strip	All Sizes	W11RWG0421-01
18	Speed Control Access Cover	All Sizes	45458-WG0808

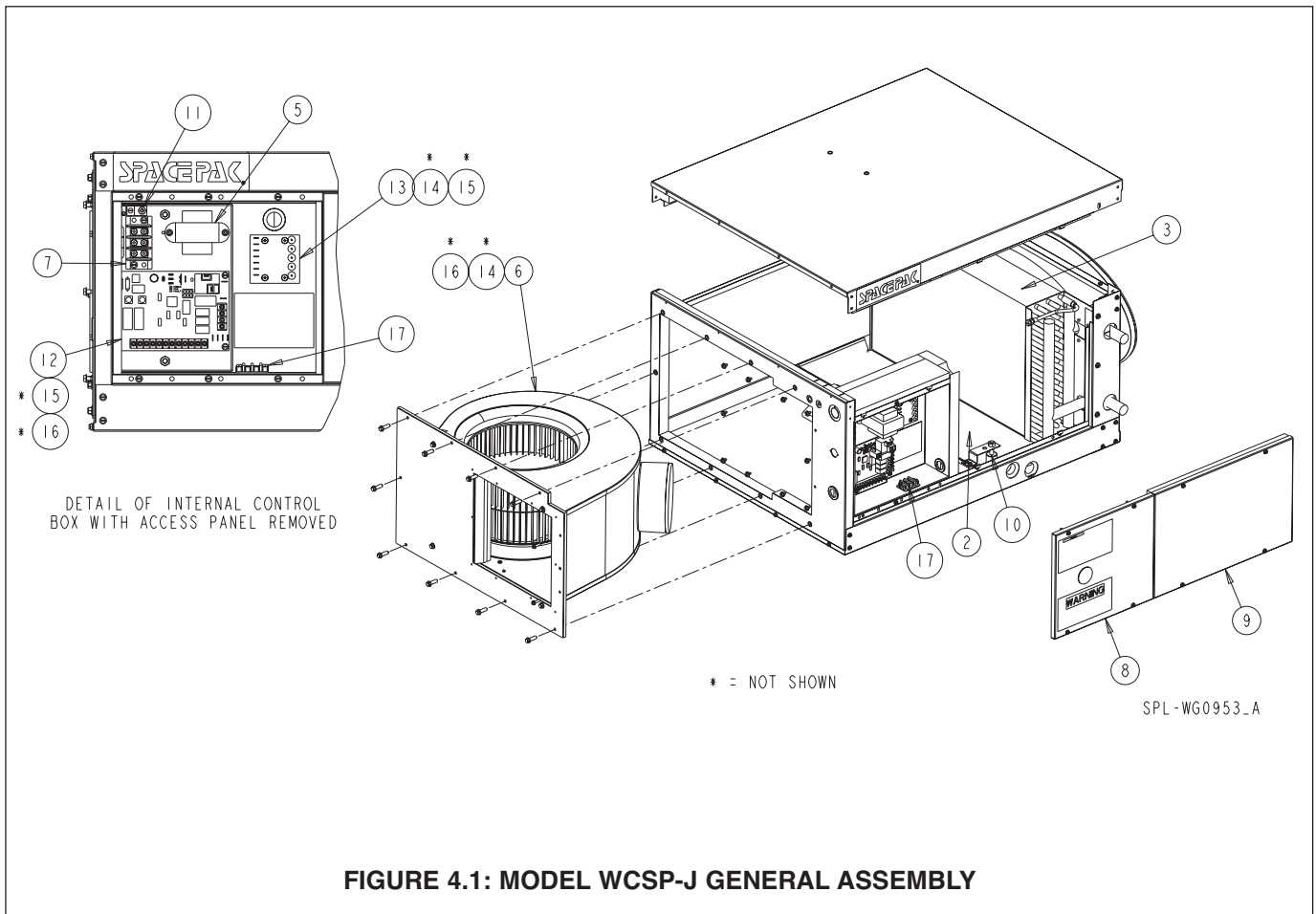

LIMITED WARRANTY

Central Air Conditioning Products

The "Manufacturer" warrants to the original owner at the original installation site that the Central Air Conditioning Products (the "Product") will be free from defects in material or workmanship for a period not to exceed one (1) year from the startup or eighteen (18) months from date of shipment from the factory, whichever occurs first. If upon examination by the Manufacturer the Product is shown to have a defect in material or workmanship during the warranty period, the Manufacturer will repair or replace, at its option, that part of the Product which is shown to be defective.

This limited warranty does not apply:

- a) if the Product has been subjected to misuse or neglect, has been accidentally or intentionally damaged, has not been installed, maintained or operated in accordance with the furnished written instructions, or has been altered or modified in any way.
- b) to any expenses, including labor or material, incurred during removal or reinstallation of the defective Product or parts thereof.
- c) to any workmanship of the installer of the Product.

This limited warranty is conditional upon:

- a) shipment, to the Manufacturer, of that part of the Product thought to be defective. Goods can only be returned with prior written approval from the Manufacturer. All returns must be freight prepaid.
- b) determination, in the reasonable opinion of the Manufacturer, that there exists a defect in material or workmanship.

Repair or replacement of any part under this Limited Warranty shall not extend the duration of the warranty with respect to such repaired or replaced part beyond the stated warranty period.

THIS LIMITED WARRANTY IS IN LIEU OF ALL OTHER WARRANTIES, EITHER EXPRESS OR IMPLIED, AND ALL SUCH OTHER WARRANTIES, INCLUDING WITHOUT LIMITATION IMPLIED WARRANTIES OF MERCHANTABILITY OR FITNESS FOR A PARTICULAR PURPOSE, ARE HEREBY DISCLAIMED AND EXCLUDED FROM THIS LIMITED WARRANTY. IN NO EVENT SHALL THE MANUFACTURER BE LIABLE IN ANY WAY FOR ANY CONSEQUENTIAL, SPECIAL, OR INCIDENTAL DAMAGES OF ANY NATURE WHATSOEVER, OR FOR ANY AMOUNTS IN EXCESS OF THE SELLING PRICE OF THE PRODUCT OR ANY PARTS THERE OF FOUND TO BE DEFECTIVE. THIS LIMITED WARRANTY GIVES THE ORIGINAL OWNER OF THE PRODUCT SPECIFIC LEGAL RIGHTS. YOU MAY ALSO HAVE OTHER RIGHTS WHICH MAY VARY BY EACH JURISDICTION.



IN UNITED STATES: 260 NORTH ELM ST. WESTFIELD, MA 01085 (413) 564-5530/FAX (413) 564-5815
IN CANADA: 7555 TRANMERE DRIVE, MISSISSAUGA, ONTARIO, L5S 1L4 (905) 670-5888/FAX (905) 670-5782

 A MESTEK COMPANY